

# Operations & Service Manual

PO-VH & OVH-10



Models: OVH-10



Models: PO-VH



## Giles Enterprises, Inc.

An ISO9001 Registered Company

2750 Gunter Park Drive West • Montgomery, AL 36109 USA

Phone: (334) 272-1457 Fax: • (334) 272-3561 • Internet: [www.gilesent.com](http://www.gilesent.com)

Service Hotline (Toll Free): 1-800-554-4537 (USA & Canada Only)

Form No. 60203 (Release date: 2/01)(Revision Date: 6/14/04)(Revision Level: B)





## LIMITED WARRANTY

- Subject to the terms and conditions of this Limited Warranty as herein stated, all Giles Enterprises, Inc., Foodservice Equipment and parts purchased new from an authorized Giles Enterprises, Inc., representative are warranted as to defects in material or workmanship for a period of 12 months from the date of installation, provided, however, that with regard to labor costs in connection with this warranty, see below. All installations must be made by a qualified installing agency in accordance with all applicable codes and/or regulations in the jurisdiction in which installed. Limited warranty coverage is extended to the original owner only and is void if the unit is resold.
- During the Limited Warranty period, Giles Enterprises, Inc. will replace or recondition, at its factory, any part or parts of this unit which Giles Enterprises, Inc. inspectors judge defective, provided the unit has been subjected to normal usage, properly installed, operated and serviced. This Limited Warranty does not cover cosmetic damage, and damage due to acts of God, accident, misuse, alteration, negligence, abuse of the Giles Foodservice Equipment or the use of unorthodox repair methods. All parts replaced under this Limited Warranty carry only the unexpired term of this Limited Warranty. Limited Warranty service may be furnished only by an authorized Giles Enterprises, Inc., representative.
- If Limited Warranty service is requested, Giles Enterprises, Inc., will send factory-authorized service representatives to repair, recondition, replace or inspect units of its manufacture with such labor being rendered without cost to owner for ninety (90) days from the date of installation. Otherwise, service, including labor and transportation charges or other expenses, in connection with the removal or installation of any part or parts supplied under this Limited Warranty, are specified on the original sales contract between the purchaser and the authorized Giles Enterprises, Inc., representative.
- Giles Enterprises, Inc. reserves the right to change or improve its equipment and parts in any way without obligation to alter such equipment or parts previously manufactured.
- Giles Enterprises, Inc. makes no further warranties, express or implied including implied warranties of merchantability or fitness for a particular purpose, and has no other obligation or liability not specifically stated herein.
- Repair or replacement as provided under this limited warranty is the exclusive remedy. Giles Enterprises, Inc., shall not be liable for any incidental or consequential damages for breach of any express or implied warranty on this product, except to the extent prohibited by applicable law. Any implied warranty of merchantability or fitness for a particular purpose on this product is limited in duration to the duration of this limited warranty.
- Used Giles Enterprises, Inc., Foodservice Equipment or parts or Giles Enterprises, Inc., Foodservice Equipment or parts not purchased from an authorized Giles Enterprises, Inc., representative, carry no warranties, express or implied.



<b>Safety</b> .....	<b>v</b>
Safety Overview .....	v
Specific Safety Precautions .....	vi
<b>1. Introduction</b> .....	<b>1</b>
1-1. Construction .....	1
1-2. Standard Features .....	1
1-3. Optional Features .....	1
1-4. Specifications .....	2
1-4.1. Overall Dimensions for PO-VH (UCM) .....	2
1-4.2. Overall Dimensions for OVH-10 (UCM) .....	3
1-4.3. Regulatory Listings .....	4
1-4.4. Hood Weights .....	4
1-4.5. Specifications of appliance installed under PO-VH .....	4
1-4.6. Specifications of appliance installed under OVH-10 .....	4
<b>2. Installation</b> .....	<b>5</b>
2-01. Location .....	5
2-02. Unpacking .....	6
2-03. Hood Electrical Requirements .....	7
2-04. Electrical Connections .....	8
2-04.1. Routing Power Wires .....	8
2-04.2. Electrical Connections when using 208/240V Appliance .....	9
2-04.3. Electrical Connections when using 480V Appliance .....	9
2-05. Bumper guard Installation (PO-VH only) .....	10
2-06. Fire Suppression System .....	11
2-06.1. General Installation .....	11
2-06.2. Piping Installation .....	12
2-06.3. Ansul System Elevation Drawing .....	12
2-06.4. Ansul System Plan Drawing .....	13
2-06.5. Ansul System Isometric Drawing .....	14
2-06.6. Ansul Parts List for figures 2-05.3., 2-05.4., & 2-05.5. ....	15
2-06.7. Ansul Fusible Link List .....	16
2-06.8. Ansul Wiring Schematic .....	16
<b>3. Overview</b> .....	<b>17</b>
3-01. Control Panel .....	18
3-02. Filter Chamber and Exhaust .....	20
3-03. Accessories (Included) .....	22

**4. Operation & Filter Maintenance . . . . . 25**

4-01. Hood Operation . . . . . 25

4-02. Filters and Filter Maintenance . . . . . 25

4-02.01. Ventless Hood Filter Table . . . . . 25

4-02.02. Filter Access Panel Removal. . . . . 26

4-02.03. Filter Access Panel Installation. . . . . 27

4-02.04. Baffle Filter Removal. . . . . 28

4-02.05. Baffle Filter Installation. . . . . 28

4-02.06. Baffle Filter Missing . . . . . 29

4-02.07. Baffle Filter Cleaning. . . . . 29

4-02.08. EAC Filter Removal. . . . . 29

4-02.09. EAC Filter Installation . . . . . 30

4-02.10. EAC Filter Status. . . . . 30

4-02.11. EAC Filter Cleaning. . . . . 31

4-02.12. Charcoal Filter Removal . . . . . 31

4-02.13. Charcoal Filter Installation . . . . . 32

4-02.14. Charcoal Filter Missing. . . . . 32

4-02.15. Charcoal Filter Replacement. . . . . 32

4-03. Filter Alarm Chart . . . . . 33

**5. Hood Cleaning and Maintenance . . . . . 35**

5-01. Hood Cleaning . . . . . 35

5-02. Fan Lubrication (OVH-10 Only) . . . . . 36

**6. Troubleshooting . . . . . 37**

6-1. Troubleshooting Procedures . . . . . 37

**7. Parts List . . . . . 39**

7-1. Parts Ordering and Service Information . . . . . 39

7-2. Fan Compartment -PO-VH . . . . . 40

7-3. Filter Compartment -PO-VH . . . . . 42

7-4. Fan Compartment -OVH-10 . . . . . 44

7-5. Filter Compartment -OVH-10 . . . . . 46

**8. Wiring Diagram . . . . . 49**

8-01. Wiring Diagram OVH-10 208-240/60/1 . . . . . 50

8-02. Wiring Diagram OVH-10 208-240/60/1 (ILS) . . . . . 52

8-03. Wiring Diagram PO-VH 208-240/60/1. . . . . 54

8-04. Wiring Diagram PO-VH 208-240/60/1 (ILS). . . . . 56

## Safety

### Safety Overview

The instructions contained in this manual have been prepared to aid you in learning the proper procedures for installing and servicing your unit.

Throughout this manual, safety precautions are identified through the use of the safety alert symbol and three signal words: **DANGER, WARNING**, and **CAUTION**. All safety alert information precedes the step(s) to which they apply. Suggested, recommended, or other noteworthy information is identified through the use of **NOTES**. Additionally, certain words are used to indicate a specific meaning or to add emphasis.

The following words are used as indicated throughout the manual:

**Shall:** understood to be mandatory.

**Should:** understood to be advisory.

**May:** understood to be permissive.

**Will:** indicates a future event/condition to occur.

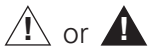

(Safety Alert Symbol)

Used in conjunction with signal words (**DANGER, WARNING**, or **CAUTION**) to alert you of potential personal injury hazards, immediately preceding precautionary measures that pertain to subsequent step(s). Obey all safety messages that follow this symbol to avoid possible injury or death. Failure to adhere to safety precautions identified by the safety alert symbol may also void the warranty.

#### **DANGER**

- Indicates an imminently hazardous situation which, if not avoided, will result in death or serious injury. Use of this is limited to the most extreme situations.

#### **WARNING**

- Indicates a potentially hazardous situation which, if not avoided, could result in death or serious injury.

#### **CAUTION**

- Indicates a potentially hazardous situation which, if not avoided, may result in minor or moderate injury. Also used to alert against unsafe practices.

#### **CAUTION**

- When used without the safety alert symbol, **CAUTION** indicates a potentially hazardous situation which, if not avoided, may result in equipment/property damage, and void the warranty.

#### **NOTE:**

- Identifies suggested, recommended, or other noteworthy information.

## Specific Safety Precautions

For your safety, please observe the following precautions when operating or servicing your Ventless Hood, Model (PO-VH & OVH-10). Read the following important safety information to avoid personal injury and/or damage to the equipment.

### **DANGER**

- Always disconnect the source of the main power before removing the service entrance box cover.
- Failure to ensure the Power switch is in the “OFF” position during servicing and when replacing filters, could result in equipment damage, electrical shock and/or personal injury.
- Failure to comply with these **DANGER** notices will result in death or serious injury, equipment/property damage, and void the warranty.

### **WARNING**

- **DO NOT** use or store gasoline or other flammable liquids or vapors in the vicinity of this or any other appliance!
- Consult a qualified electrician to ensure all electrical specifications have been met and the unit is properly grounded.
- Before installing or servicing this equipment, read the contents of this manual thoroughly.
- Improper installation, adjustment, alteration, service or maintenance could result in death or serious injury, equipment/property damage, and void the warranty.
- Failure to comply with these **WARNING** notices could result in death or serious injury and equipment/property damage.

### **CAUTION**

- Maintain a minimum clearance of 12” (304.8mm), 18” (457.2mm) recommended, between the hood outlet and the ceiling or any obstruction above the hood.
- Exercise care when lifting or moving the unit. See Section 1-3.5. Hood Weights
- Exercise care when removing the wooden crate from around the unit.



## CAUTION

- **DO NOT** operate the unit unless you fully understand the components and their intended function.
- Be careful not to bend the fins or break the ionized wires on the EAC (Electrostatic Air Cleaner) as this will prevent the EAC from working properly and shut off the power to the appliance being used with the hood.
- Failure to comply with these **CAUTION** notices may result in minor or moderate injury, equipment/property damage, and void the warranty.

## CAUTION

- The electronic components of the Control Panel are impact-sensitive. Exercise care around the Control Panel to maintain proper operation.
- Do not try to dry the EAC either by running the hood to air dry or by running the appliance below the hood to heat dry. This could potentially damage the EAC causing improper operation and voiding the warranty.
- During cleaning of Hood.
  - **DO NOT** steam clean.
  - **DO NOT** use products containing chlorine.
  - **DO NOT** use abrasive products, steel wool or scouring pads.
- Failure to comply with these **CAUTION** notices may result in equipment/property damage and void the warranty.

## NOTE:

- If the crate in which the unit arrives is damaged, immediately inspect the Ventless Hood and notify the carrier of any damage to the unit.
- To aid the electrician, an electrical wiring diagram is contained in this manual. Refer to the wiring diagram during installation or servicing.
- Comply with all appropriate state and/or local health regulations regarding the cleaning and sanitation of equipment.
- For difficult areas with excessive particulate build up, a mild degradable nontoxic degreaser (such as Clear Magic or Simple Green) may be used.
- Always ensure the unit is electrically grounded and installed in accordance with local codes, or in the absence of local codes, in accordance with the National Electrical Code ANSI/NFPA No. 70-1984.

**NOTE:**

- The Exhaust Fan in OVH-10 should be lubricated at least every six (6) months!
- The decibel level of the hood when operating is approximately 65 dB's.

## 1. Introduction

Congratulations on the purchase of your new Giles Ventless Hood System (PO-VH or OVH-10) manufactured by Giles Enterprises, Inc., Montgomery, Alabama (USA), hereafter referred to as "Giles". Two different models, PO-VH and OVH-10, are as a ceiling mounted or direct mounted. Proper care and maintenance of this unit will ensure years of trouble-free service.

To help protect your investment in this equipment, we recommend taking a few moments to familiarize yourself with the installation, cleaning and maintenance procedures contained in this manual. Read these instructions before installation and use. Adherence to these recommended procedures minimizes the potential for costly "down-time" and equipment repairs. Please retain this manual for future reference.

### 1-1. Construction

The Ventless Hood System exterior is constructed of stainless steel.

### 1-2. Standard Features

#### Control Panel

- Control panel LED indicators for monitoring status of the EAC filter.
- Missing Filter Light indicating Charcoal and/or Baffle filter missing.

#### Filters

- Baffle Filter -used for grease extraction.
- Electronic Air Cleaner (EAC) -used to capture smoke & other air contaminants.
- Charcoal Filter -used to remove odor.

#### Skirt Configuration

- PO-VH & OVH-10 are designed to allow customization of skirts to a wide variety of oven configurations.

### 1-3. Optional Features

#### Interlocking Start System (ILS)

- Inlocking Start System (ILS) -This system will cause the Hood and the Appliance below the Hood to shut down when the hood filters need to be clean or are not properly installed. This system is required by some cities and/or states. Please check with your local code officials to see if this system is required.

## 1-4. Specifications

### 1-4.1. Overall Dimensions for PO-VH (UCM)

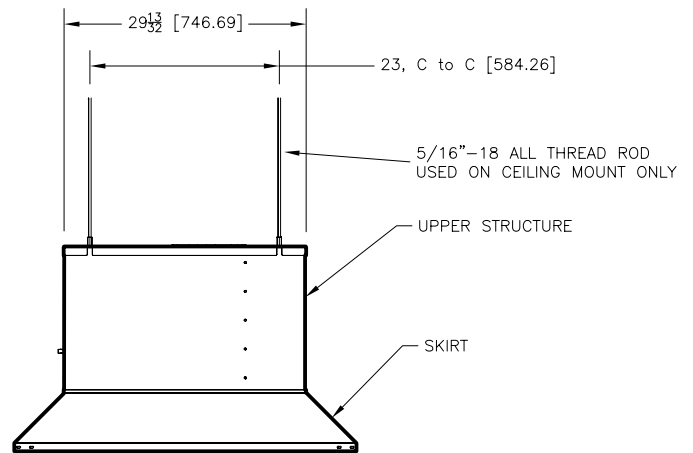
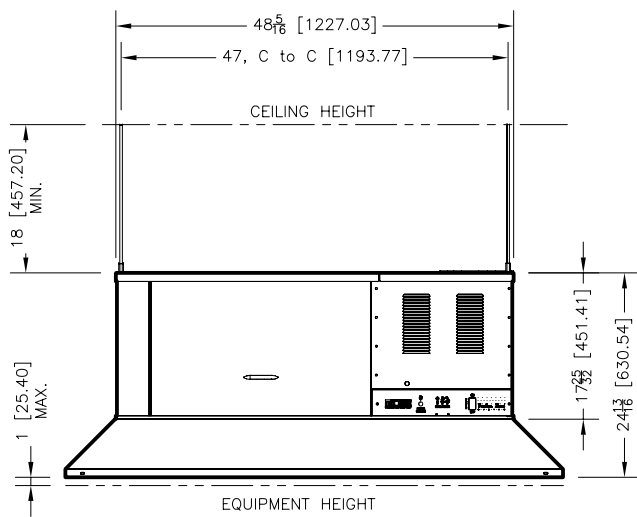
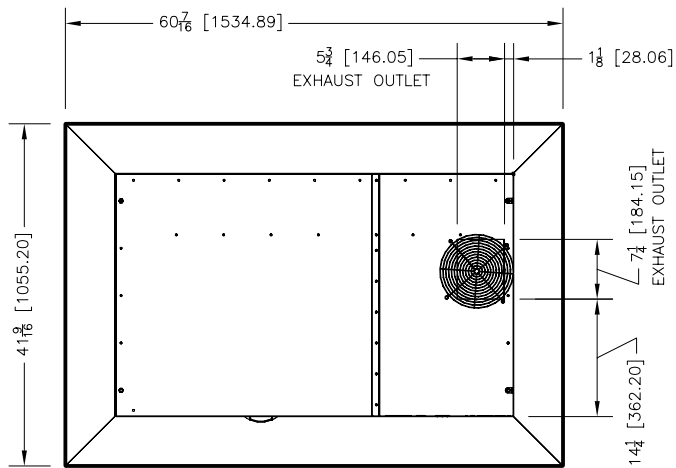

## 1-4.2. Overall Dimensions for OVH-10 (UCM)

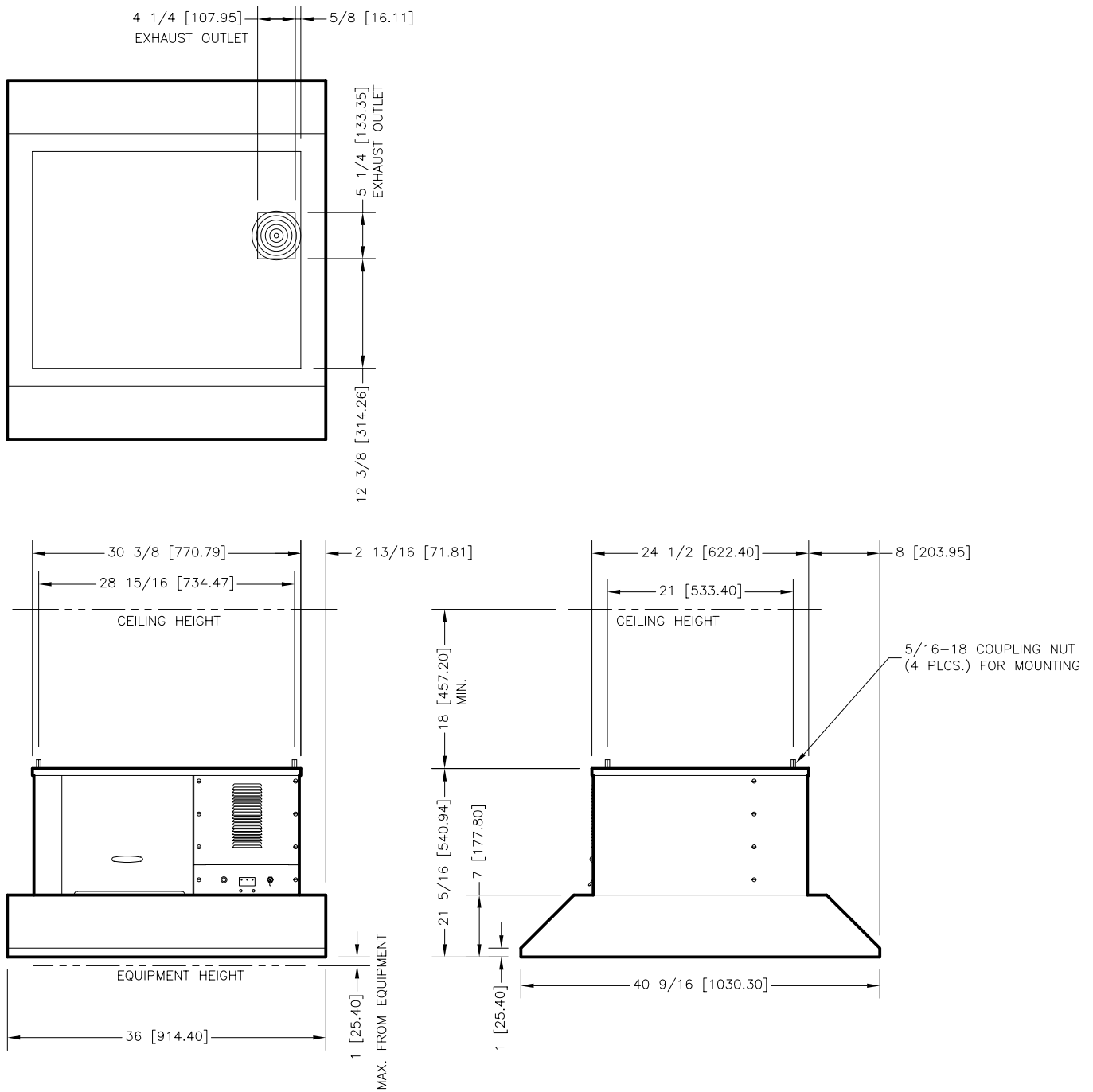

**1-4.3. Regulatory Listings**

UL (US and Canada)  
 NSF  
 CE

**1-4.4. Hood Weights**

Hood	Crated Weight	Uncrated Weight
PO-VH	337 lbs [152.8 kg]	221 lbs [100.2 kg]
OVH-10	221 lbs [100.2 kg]	130 lbs [58.9 kg]

**1-4.5. Specifications of appliance installed under PO-VH**

Maximum Kilowatts of appliance installed under the hood		
Unit Type	Max. Total Input, kW	Max Clearance
Electric Oven (May be double stacked)	50	30" [762mm] to cooking surface
Electric Rotisserie	6	6" [153] to door top

**1-4.6. Specifications of appliance installed under OVH-10**

Maximum Kilowatts of appliance installed under the hood		
Unit Type	Max. Total Input, kW	Max Clearance
Electric Oven (May be double stacked)	11.5	30" [762mm] to cooking surface
Electric Rotisserie	6	6" [153] to door top

## 2. Installation

This section provides a summary of procedures necessary to install your new PO-VH or OVH-10. Before installing or servicing this equipment, please read the contents of this manual thoroughly. Following these procedures will help ensure a safe and proper installation.

### 2-01. Location

**NOTE:**

- The decibel level of the hood when operating is approximately 65 dB's.

**⚠ CAUTION**

- **DO NOT MODIFY, ALTER OR ADD ATTACHMENTS TO THIS EQUIPMENT**

1. Do not obstruct the exhaust air outlet. Maintain a minimum clearance of 12 inches (304.8mm) between the Hood air outlet (located on top of the unit) and the ceiling or any obstruction, **18" (457.2mm) clearance is recommended.**

## 2-02. Unpacking

Your Ventless Hood should arrive packaged in a wooden crate, covered with plastic shipping wrap, and secured to a wooden platform by means of high-tensile strength strapping. Perform the following steps to uncrate the unit:

1. Position the packaged unit in an area with sufficient room for unpacking.

**NOTE:**

- If the crate is damaged, immediately inspect the Ventless Hood and notify the carrier of any damage to the unit.

2. The Hood is shipped from the factory top side down in the crate. Cut and remove the plastic shipping wrap and any high-tensile strength straps from the exterior of the wooden crate.

3. Use a hammer and pry-bar to remove the wooden crate from around the unit.

 **CAUTION**

- Exercise care when lifting or moving the unit, please see Section 1-3.5 for hood weights.
- Exercise care when removing the wooden crate from around the unit.
- Failure to comply with these **CAUTION** notices may result in minor or moderate injury, equipment/property damage, and void the warranty.

4. Carefully follow the separate Mounting Instructions shipped with the hood.



## 2-03. Hood Electrical Requirements

**⚠ WARNING**

- Consult a qualified electrician to ensure all electrical specifications have been met and that the unit is properly grounded.
- Improper installation, adjustment, alteration, service or maintenance could result in death or serious injury, equipment/property damage, and void the warranty.

Hood Electrical Requirements						
Unit	Voltage	Hz	Phase	Watts	Amps	Breaker
OVH-10	208	60	1	433	2.1	10
OVH-10	240	60	1	433	1.8	10
PO-VH	208	60	1	920	4.4	10
PO-VH	240	60	1	920	3.8	10
PO-VH	220	50	1	920	4	10

## 2-04. Electrical Connections

1. Install appropriate Circuit Breakers in Main Breaker Box. See Table 2-03.
2. Connect appropriate size Power Cable wire to the Main Breaker. Allow enough Cable so the unit can be moved for cleaning and servicing.
3. Remove the Service Panel. See Figure 2-04.1.
4. Run the Power Cable to the unit.
5. If the Unit is to be installed above a 208/240V Appliance connect appropriate Power wires to the Hood Contactor. See 2-04.2

If the Unit is to be installed above a 480V Appliance, remove Terminal Block Jumpers from the Hood Terminal Block, connect appropriate 208/240 supply Power wires to the Hood Terminal Block, and connect 480V appliance supply power to the Hood Contactor. See 2-04.3

6. Connect Appliance power from Hood Contactor to the Appliance.
7. Reinstall Service Panel.
8. Turn Main Breaker on.
9. Press the Hood Power Switch to the ON position. (If using the ILS option, with the Power Switch in the ON position press and hold Start Button)

### 2-04.1 Routing Power Wires

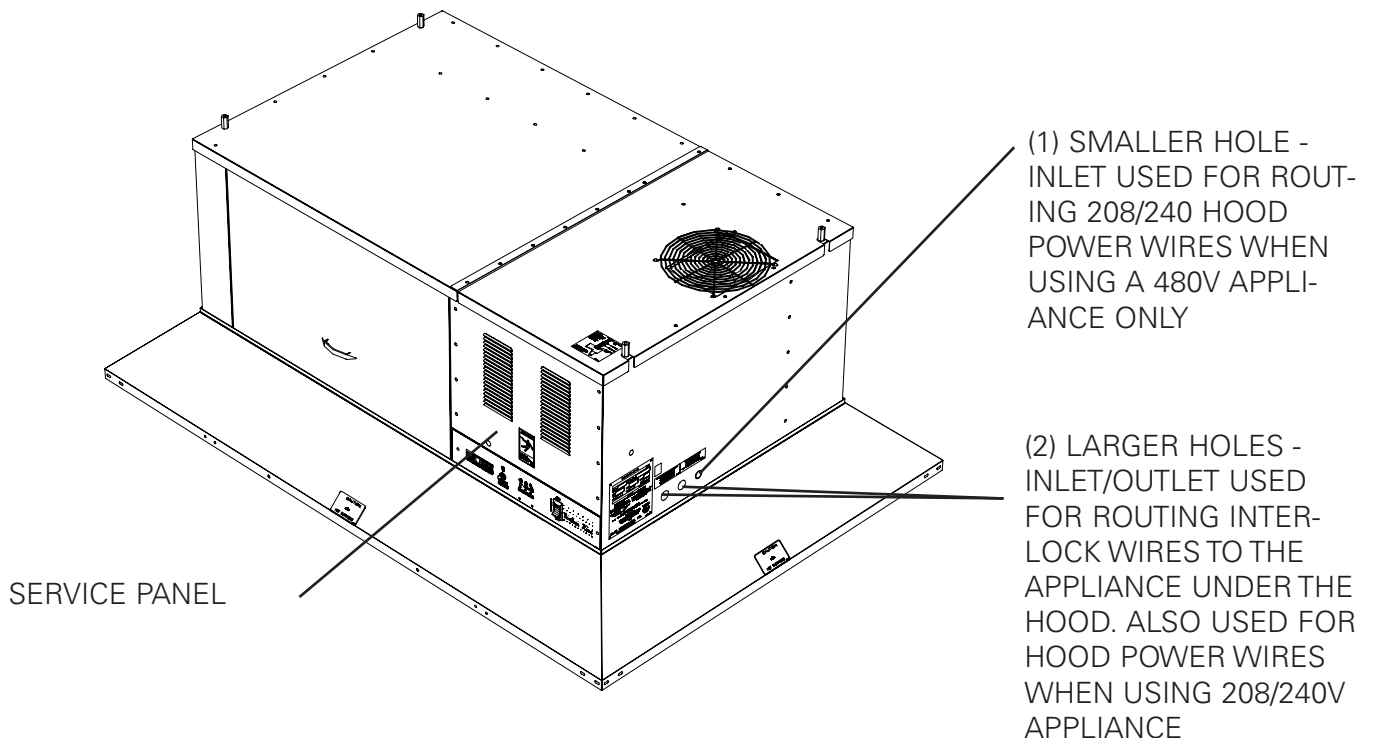

## 2-04.2 Electrical Connections when using 208/240V Appliance

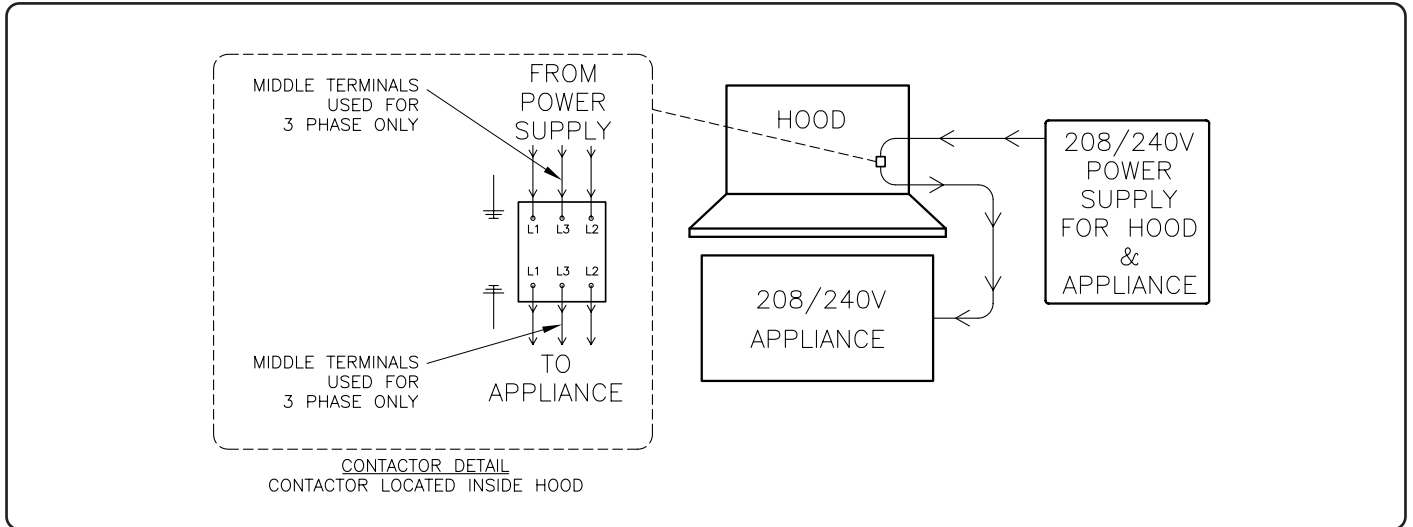

## 2-04.3 Electrical Connections when using 480V Appliance

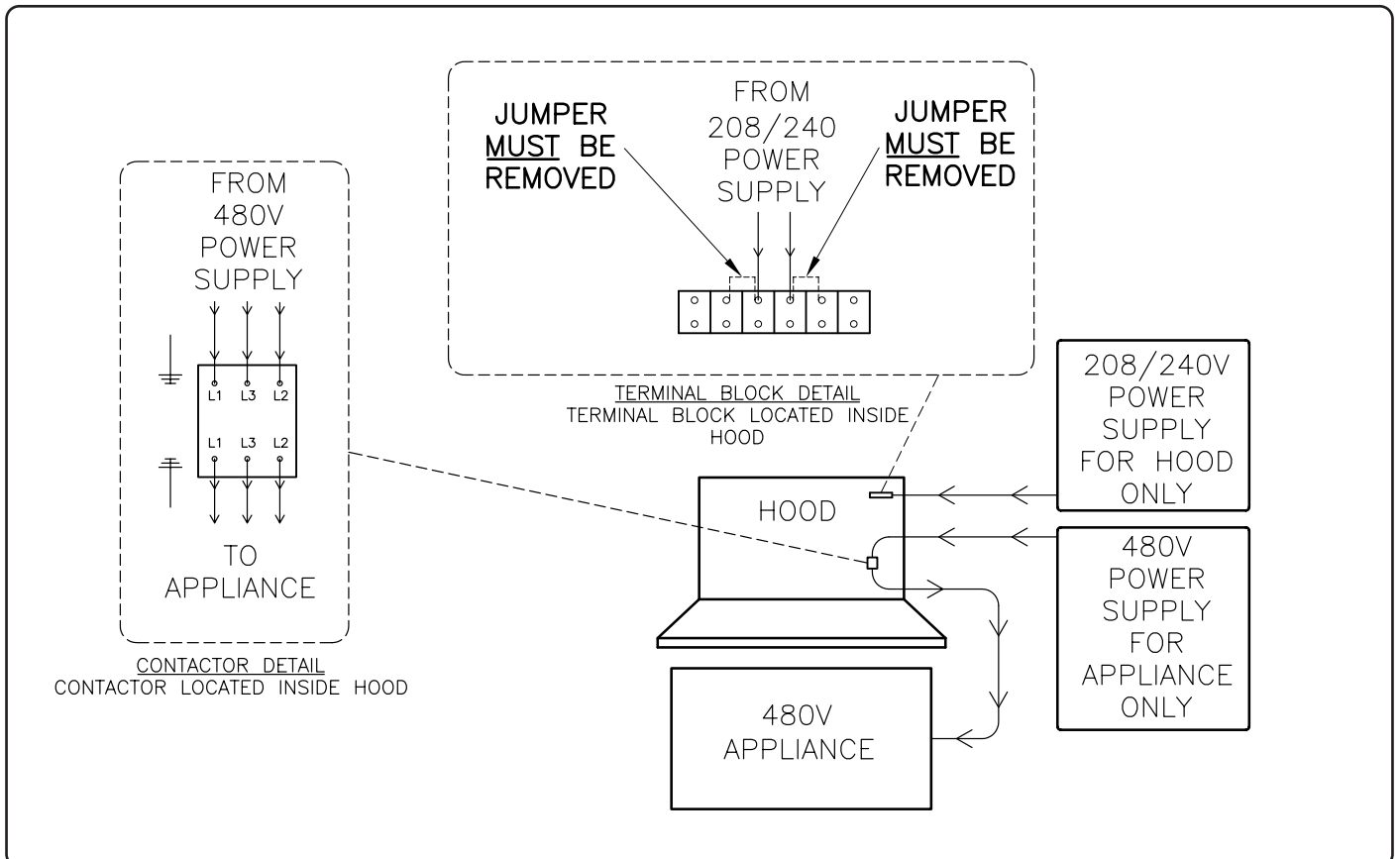

## 2-05. Bumper guard installation (PO-VH only)

Your PO-VH is shipped with (2) bumper guards to protect against potential injury to persons coming in contact with the overhanging corners of the hood. After the Hood has been installed, attach the Bumpers to the two exposed hood corners.

1. Position bumper to match with holes.
2. Insert 8-32 x 3/4 screw through holes in the bumper.
3. Screw 8-32 nut onto screw on inside of hood skirt.
4. Tighten screw and nut.
5. Place bumper caps in hole over screw head.

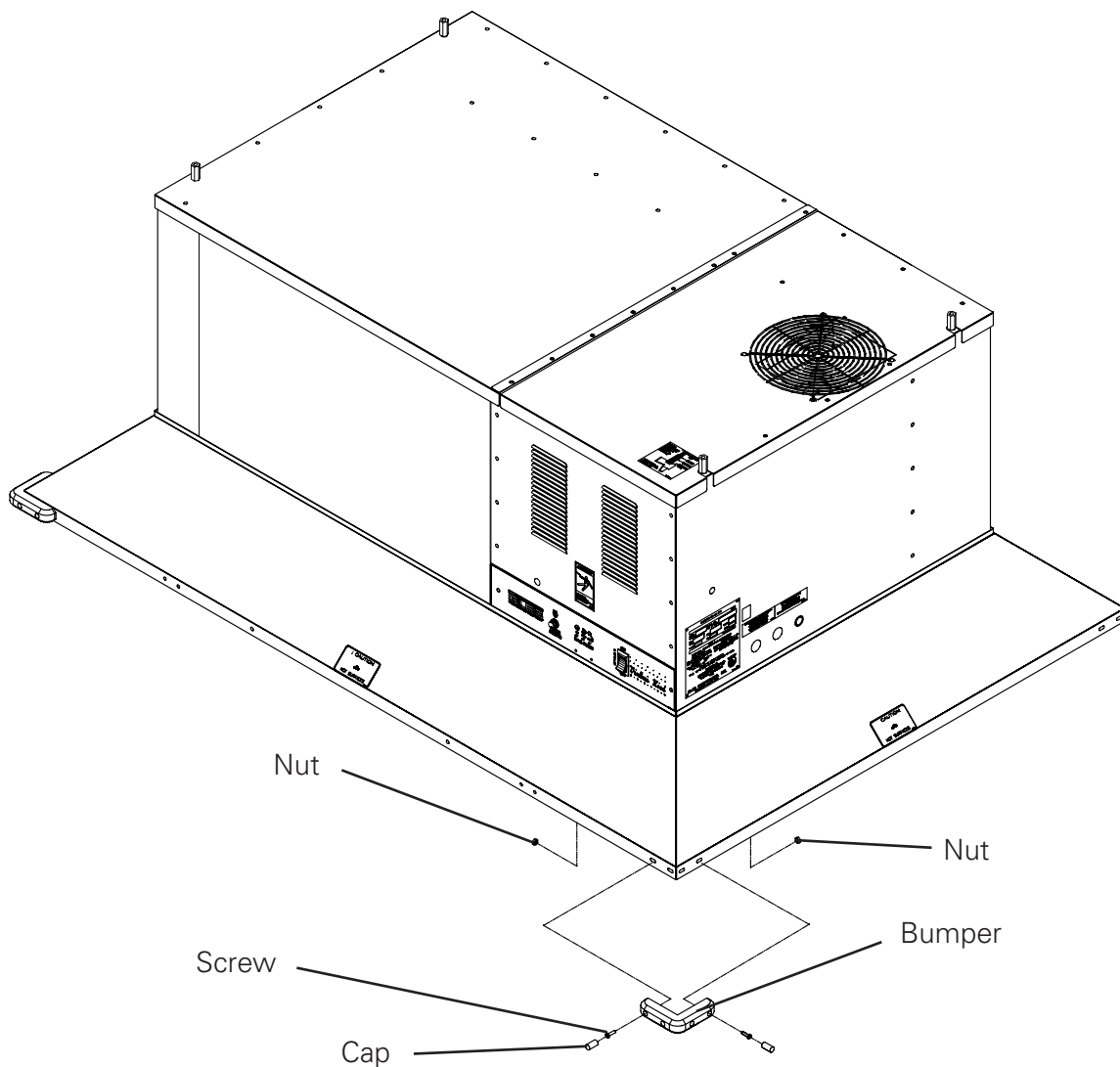

## 2-06. Fire Suppression System

Some local jurisdictions require Fire Suppression Systems be installed in all hoods, regardless of their use. If yours is such a jurisdiction, please refer to the illustration instructions covered in this section.

Service of the fire suppression system is to be conducted by qualified fire equipment personnel. The extinguishing system should be maintained as outlined in the Standard of Wet Chemical Extinguishing Systems, NFPA 17A.

### 2-06.1. General Installation

1. This installation is to be made in accordance with the R-102 installation manual and in accordance with all state and local codes.
2. All pipe lengths to be field verified.
3. These drawings may be used to secure approval from the authority having jurisdiction.
4. It is necessary all pipe fittings and nozzles be wrench tightened and securely supported and all nozzles are properly aimed as indicated in the R-102 installation manual.
5. The wire rope for the detector and remote pull station is to be installed by an authorized and factory trained distributor or service representative.
6. This installation is to be inspected, put into operation and certified by an authorized and factory trained distributor or service representative.
7. Electrical contractors and wiring for appliance shut-off to be provided by the electrical contractor.
8. When installed as shown on the following drawings the system will comply with all relevant Ansul installation, inspection, and maintenance manuals and shall comply with NFPA 96 when installed and certified by authorized trained Ansul distributors in accordance with the R-102 manual.
9. All agent distribution piping and detection conduit hood penetrations must be properly sealed in accordance with NFPA 96.

## 2-06.2. Piping Installation

1. Pipe shall be 1/4:" schedule 40 black iron, chrome plated or stainless steel.
2. Pipe ends shall be reamed and blown clear of chips and scale before assembly. Inside of pipe and fittings must be free of oil and dirt.
3. Piping dimensions given are from center of fittings.

## 2-06.3. Ansul System Elevation Drawing

See Section 2-05.6 for Parts List

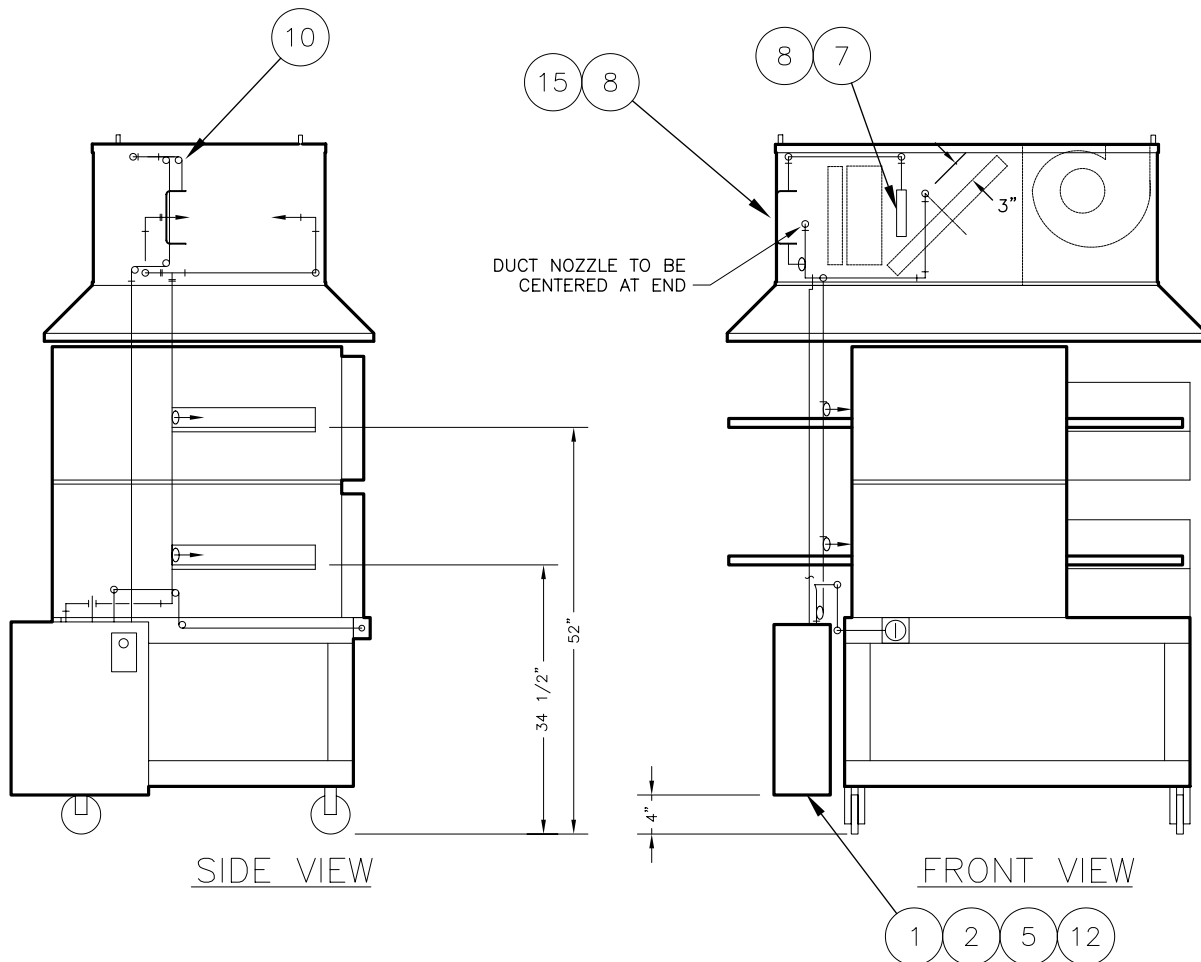

## 2-06.4. Ansul System Plan Drawing

See Section 2-05.6 for Parts List

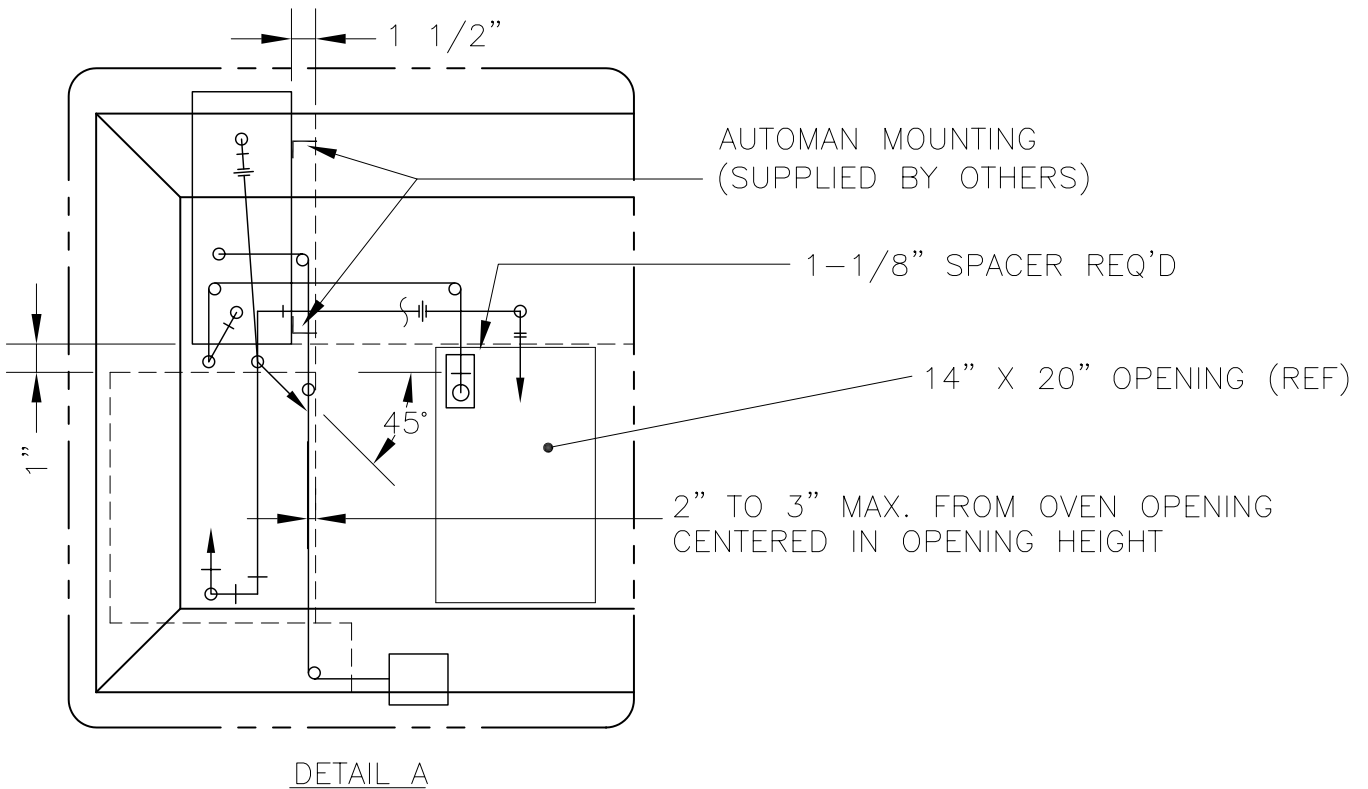
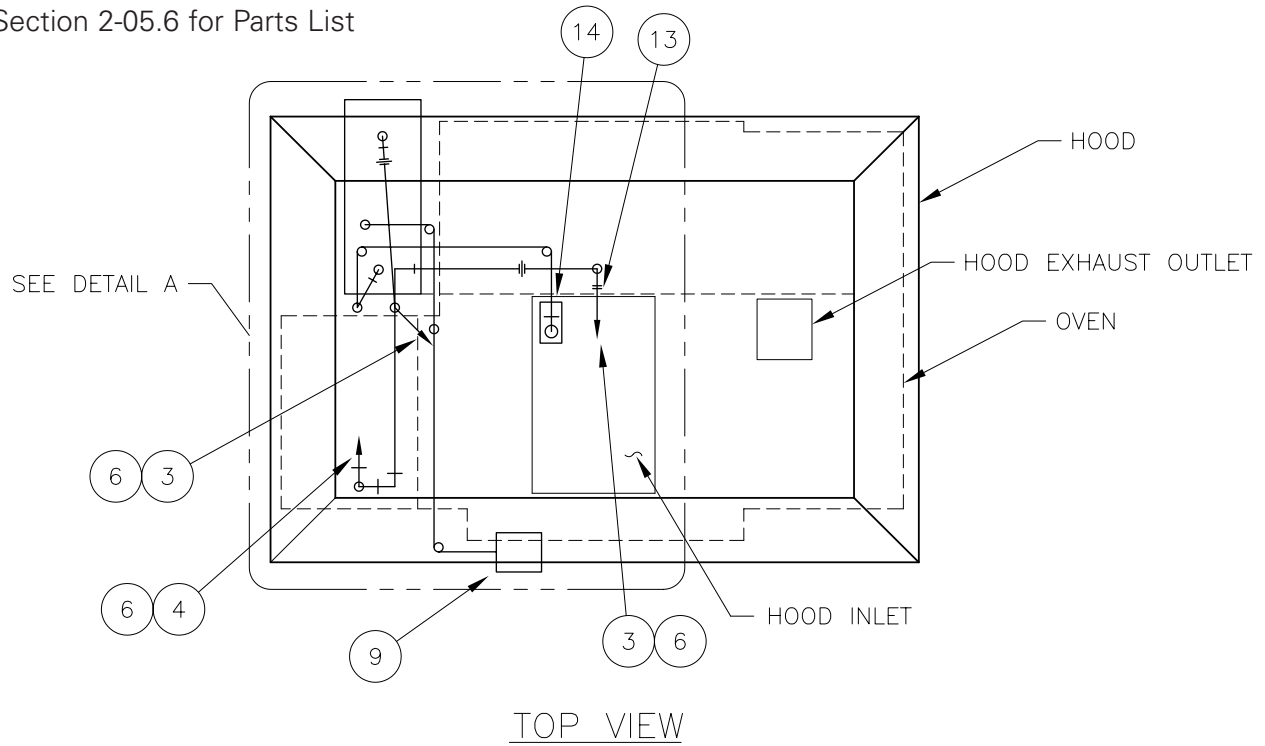

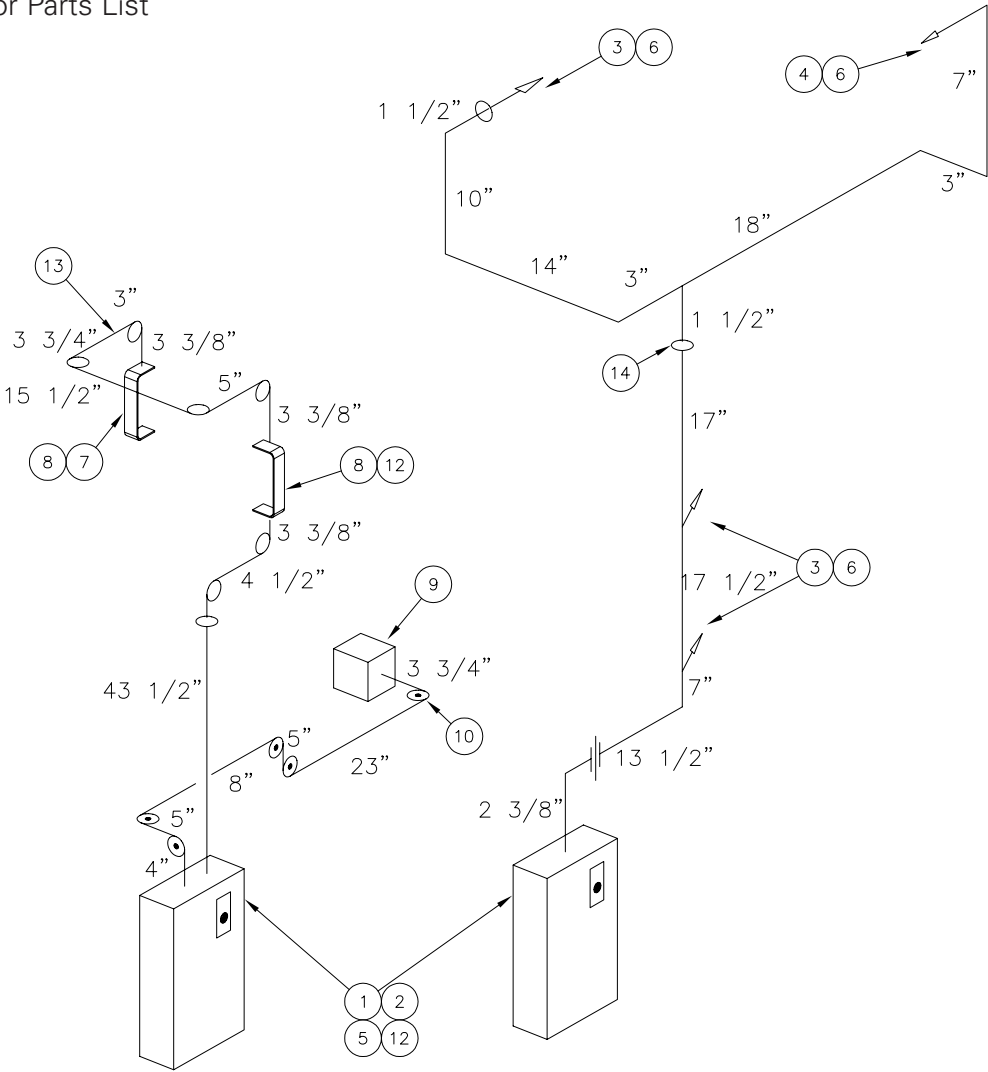

2-06.5. Ansul System Isometric Drawing

See Section 2-05.6 for Parts List



ISOMETRIC VIEW

Conduit Piping Notes: Conduit runs are dimensioned center to center of conduit. Except:

- A. To face(s) of detector bracket(s).
- B. To top surface Automan.
- C.  Shows location for pulley cover screws.  
 Shows backside of pulley elbow.



## 2-06.6. Ansul Parts List for figures 2-05.3., 2-05.4., & 2-05.5.

Parts List for Ansul Installation			
Item No.	Ansul P/N	Description	# Req'd
1	77952	1.5 Gal Mech. Ansul Automan Reg Release Mechanism	1
2	78091	1.5 Gal Ansulex	1
3	56930	Nozzle Assembly (Appliance)	3
4	78078	Nozzle Assembly (High Flow Duct)	1
5	7032	Cartridge Shipping Assembly (LT-20-R)	1
6	77411	Blow Off Caps	4
7	56838	Terminal Detector Package	1
8	56811	Fusible Link Type ML 165°F (73.9°C)(See Fuse Link List)	1
9	4835	Remote Pull Station Assembly	1
10	78195	Pulley Elbow Assembly	10
11	15821	Wire Rope (not shown)	1
12	32222	Electric Switch – DPDT	1
13	78195	1/4" Quick Seal Adapter	2
14	77286	1/2" Quick Seal Adapter	2
15	56837	Series Detector Package	1

Note: All part numbers given are Ansul part number's and should be ordered from an Ansul dealer.

## 2-06.7. Ansul Fusible Link List

Fusible Link List		
P/N	Temp	To be Used Where Temp DOES NOT EXCEED
56810	135° (57°C)	70°F (21°C)
56811	165°F (74°C)	100°F (38°C)
56812	212°F (100°C)	150°F (66°C)
56813	280°F (138°C)	225°F (107°C)
56814	360°F (182°C)	290°F (143°C)
56815	450°F (232°C)	360°F (182°C)
56816	500°F (260°C)	400°F (204°C)

## 2-06.8. Ansul Wiring Schematic

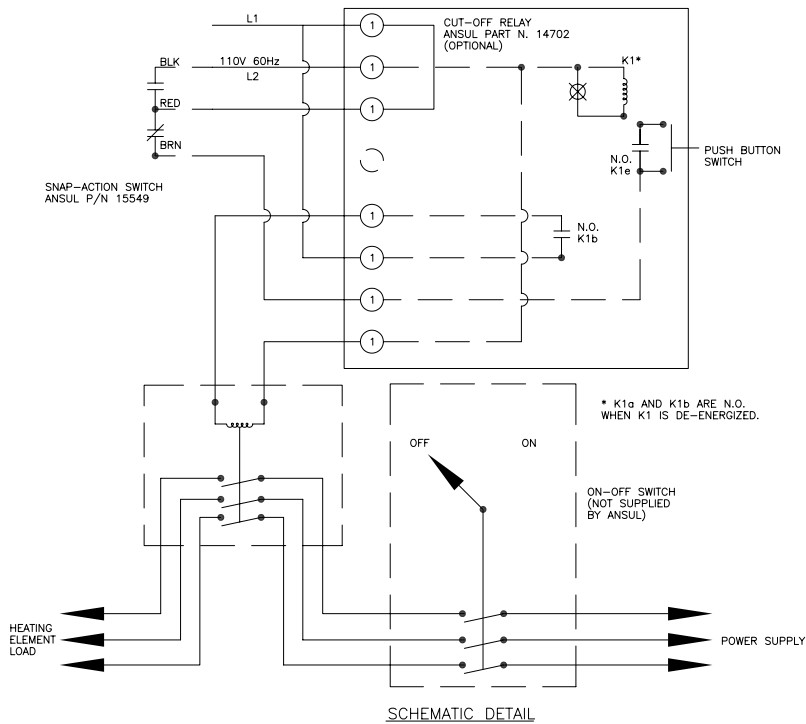

## 3. Overview

The following section provides a brief overview of the components, functions, and accessories of the PO-VH and the OVH-10. Please review this section carefully before proceeding any further.

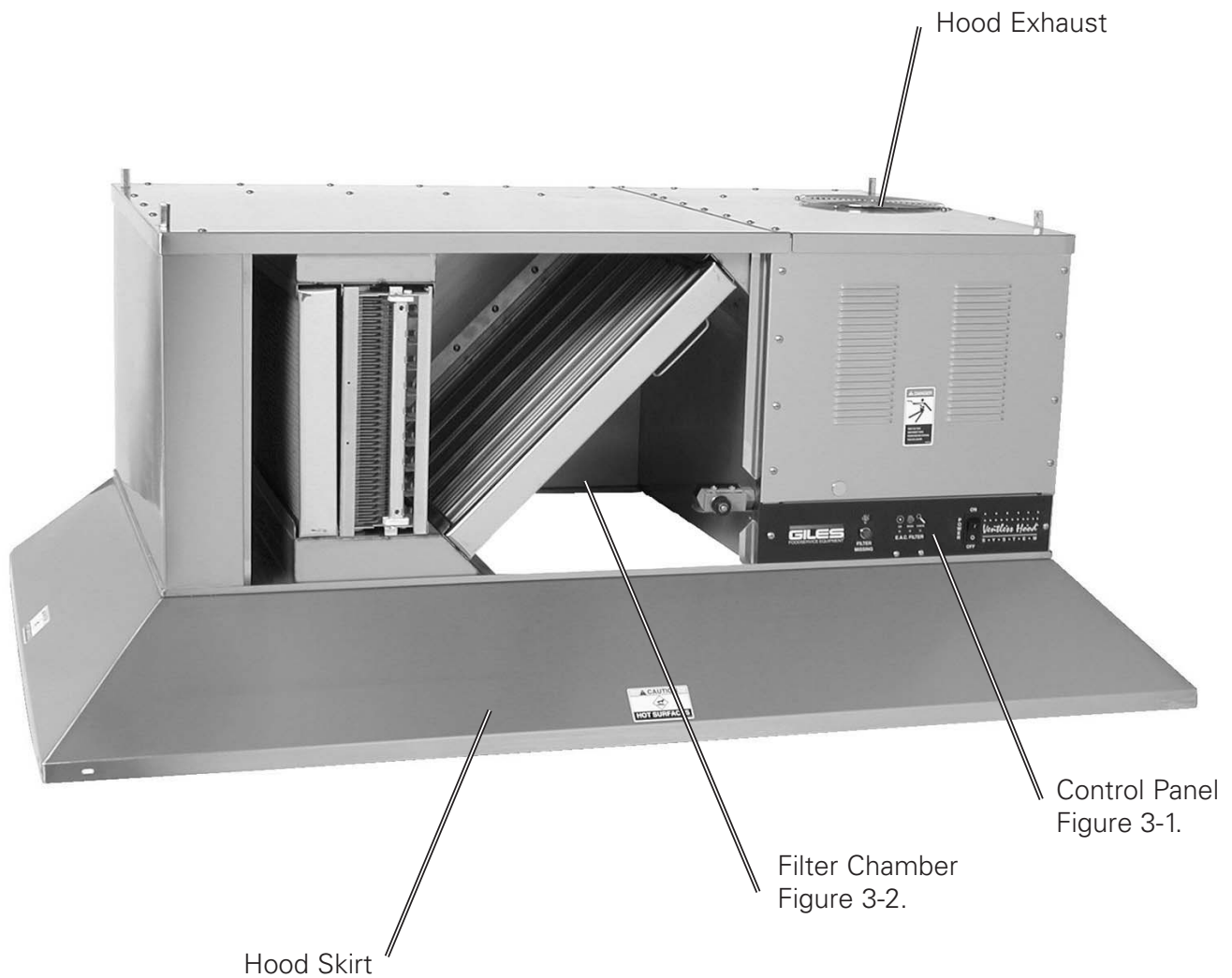

3-01. Control Panel

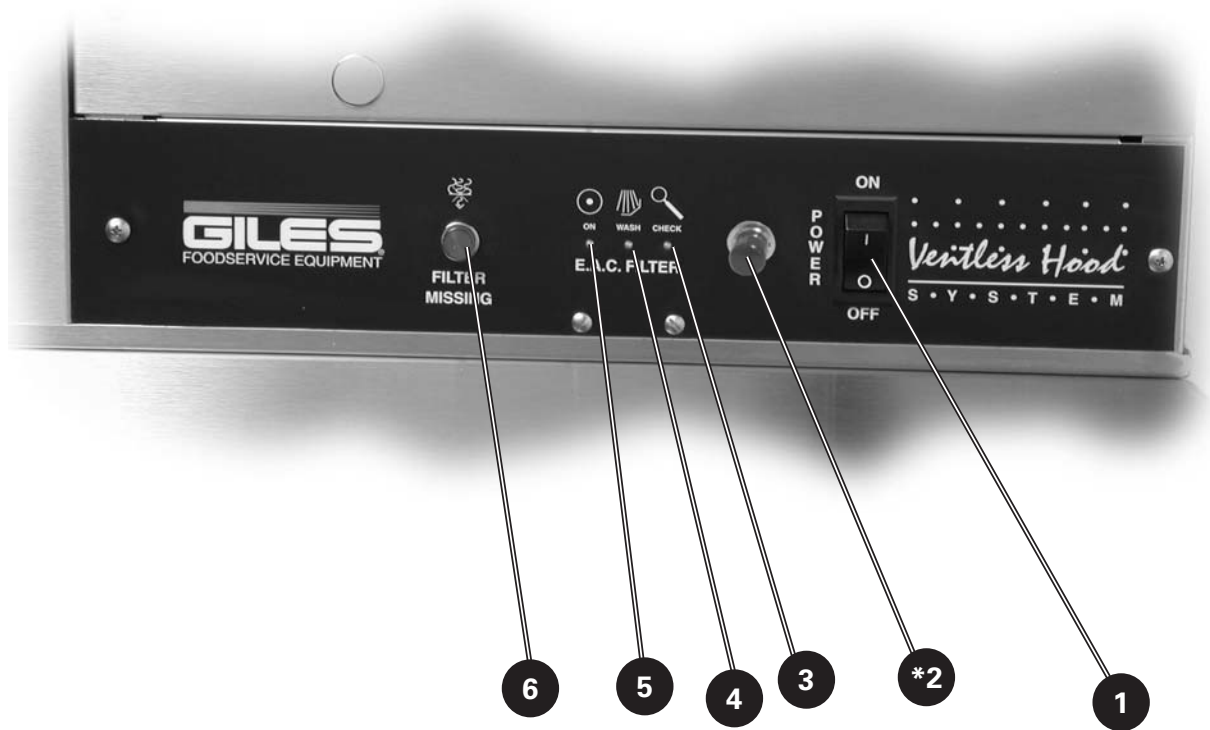

\* -Interlocking Start (ILS) Only

3-01. Control Panel		
Item	Description	Function
1	Power Switch	The Power Switch is a two-position Switch. Move the switch upward to the "ON" position for operation.
*2	PUSH to START Button	After the Power Switch is in the "ON" position, push and hold down "PUSH to START" Button for 5 seconds. (Used only in units with ILS (Interlocking Start)).
3	CHECK Indicator Light	The "Check" Indicator Light illuminates when the EAC becomes shorted and indicates the EAC needs cleaning or repair.
4	WASH Indicator Light	The "Wash" Indicator Light will come on when the EAC becomes excessively dirty. Do not use this light as a signal for routine cleaning of the EAC. Failure to clean the EAC daily will significantly decrease the life of the charcoal filter. Clean the EAC daily for best performance.
5	ON Indicator Light	The "ON" Indicator Light illuminates when the Electronic Air Cleaner (EAC) power supply is on.
6	Filter Missing Light	The "Filter Missing" Light illuminates when the Grease Baffle Filter or the Charcoal Filter are not properly positioned.

\* -Interlocking Start (ILS) Only

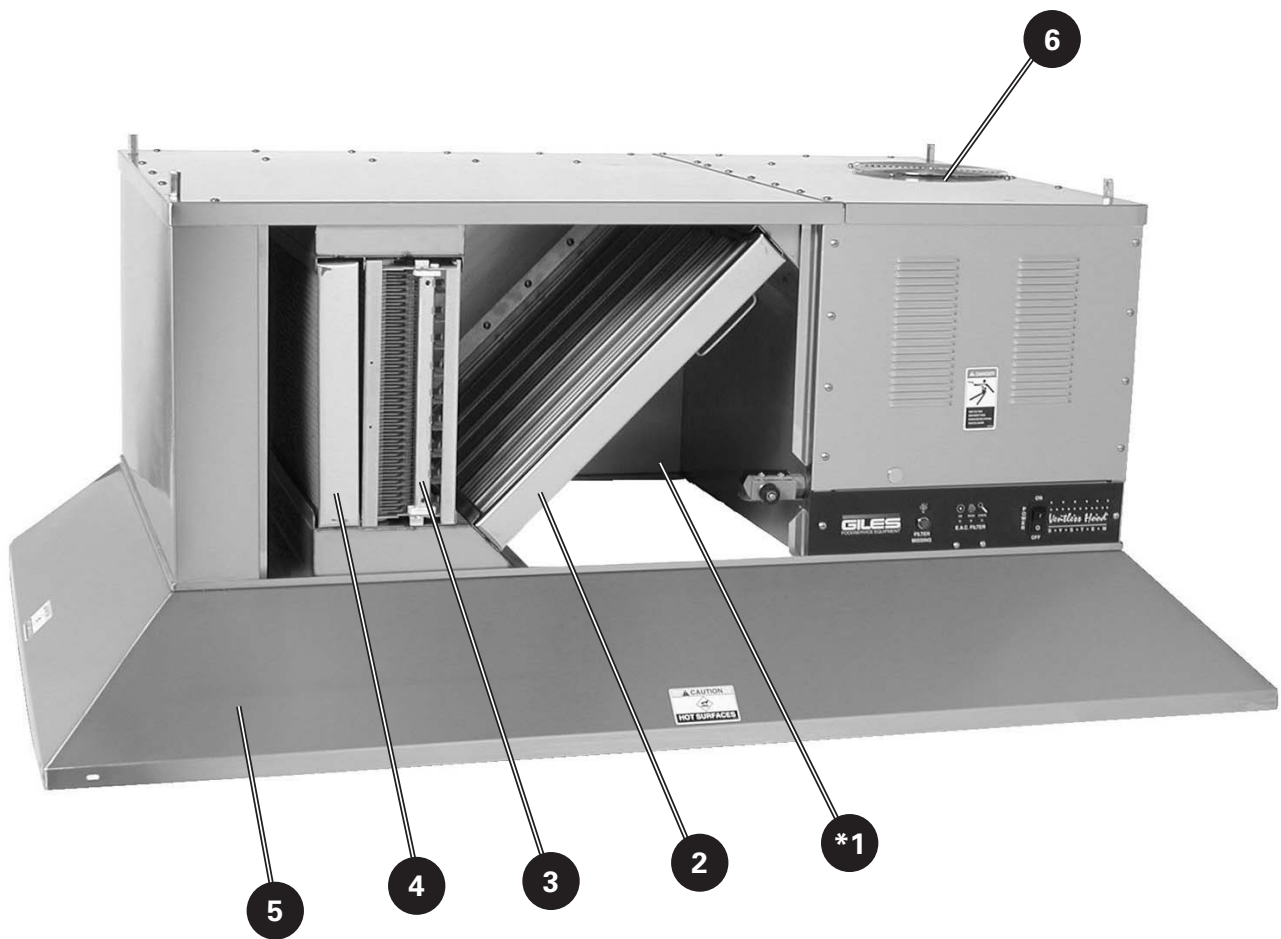

3-02. Filter Chamber and Exhaust



\* -Not Shown



3-02. Filter Chamber and Exhaust		
Item	Description	Function
*1	Hood Filter Cover	Used to access the EAC and Charcoal Filters. This cover must be in place and latched for the unit to operate.
2	Baffle Filter	The Baffle Filter is the first stage of the grease extraction and air-cleaning system found on these units. It is easily removed for daily cleaning. <b>DO NOT remove the Baffle Filter while the hood is operating to prevent contact with electrical parts and avoid electrical shock. The Baffle Filter should be cleaned daily.</b>
3	EAC Filter	The EAC Filter is an electrical device which removes grease vapor and smoke generated by the appliance during cooking. <b>DO NOT remove the EAC Filter while the hood is operating to prevent contact with electrical parts and avoid electrical shock. The EAC should be cleaned daily.</b>
4	Charcoal Filter	The Charcoal Filter helps to remove odors generated during cooking. This Filter should be replaced monthly. <b>DO NOT remove the Charcoal Filter while the hood is operating to prevent contact with electrical parts and avoid electrical shock. NEVER attempt to clean and reuse a Charcoal Filter.</b>
5	Hood Skirt	Used to help air capture from the appliance. Skirt designs vary depending on the appliance the hood is being placed over.
6	Exhaust Outlet	Located on top of the unit. <b>Allow the recommended clearance of 18" (12" minimum) between the top of the Exhaust Outlet and the ceiling or any obstructions.</b>

\* -Not Shown

<b>3-03. Accessories (Included)</b>		
<b>Part</b>	<b>Description/Part Number</b>	<b>Function</b>
	<p>Baffle Filter                      P/N 42300 (PO-VH)                      P/N 45096 (OVH-10)</p>	<p>Used for removing smoke and contaminants from the air</p>
	<p>EAC Filter                      P/N 20520 (PO-VH)                      P/N 22360 (OVH-10)</p>	<p>Used for removing smoke and contaminants from the air</p>
	<p>Charcoal Filter                      P/N 31964 (PO-VH)                      P/N 31963 (OVH-10)</p>	<p>Used for removing odors from the air</p>





3-03. Accessories (Included)		
Part	Description/Part Number	Function
	EAC Soak Tank P/N 39327	Used for cleaning EAC filter.
	Bumper (2) (PO-VH Only) P/N 40250	Used to protect PO-VH Hood Skirt exposed corners



**Notes:**

## 4. Operation & Filter Maintenance

This section describes the operation of and the filter maintenance for the Ventless Hood.

### 4-01. Hood Operation

This section describes how to start the Ventless Hood. Make sure all the Filters are in place before operating the unit.

1. Press the Power Switch to the ON **1** position, (if ILS, then press and hold the "Push and Hold to Start" **2** switch, for 5 seconds) and EAC On light **3** will illuminate.

This will turn the Hood on and the Hood Fan will begin running. The appliance under the hood, if interlocked to the hood, may now be turned on.

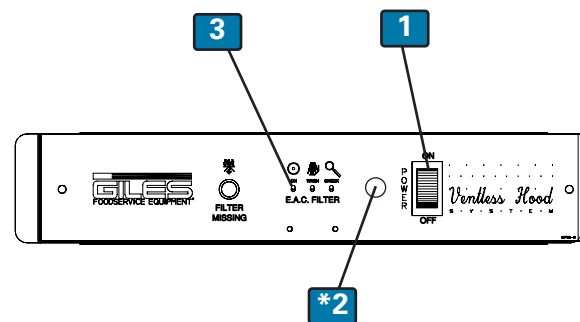

\* -ILS only

### 4-02. Filters and Filter Maintenance

This section describes each Filter in the Ventless Hood.

#### 4-02.01. Ventless Hood Filter Table

Filter	When to clean or replace	How to remove	How to clean	How to install
Baffle Filter	Clean daily	Section 4-02.06	Section 4-02.07	Section 4-02.08
EAC Filter	Clean daily	Section 4-02.08	Section 4-02.11	Section 4-02.09
Charcoal Filter	Replace every 30 days, P/N 31964 (PO-VH) P/N 31963 (OVH-10)	Section 4-02.12.	<b>Never clean, only replace</b> Section 4-02.15	Section 4-02.13.

4-02.02. Filter Access Panel Removal

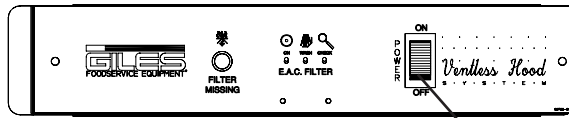

1 Place in OFF position

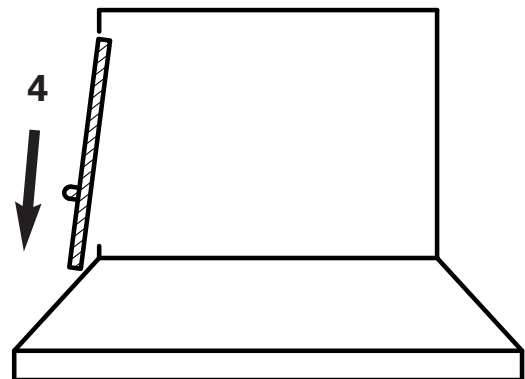
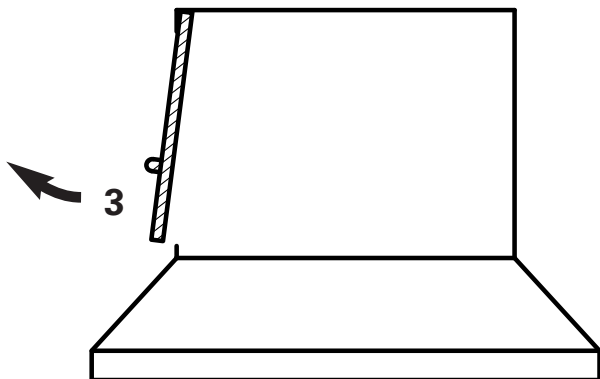
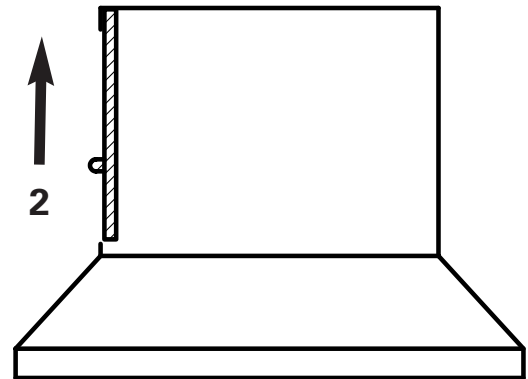
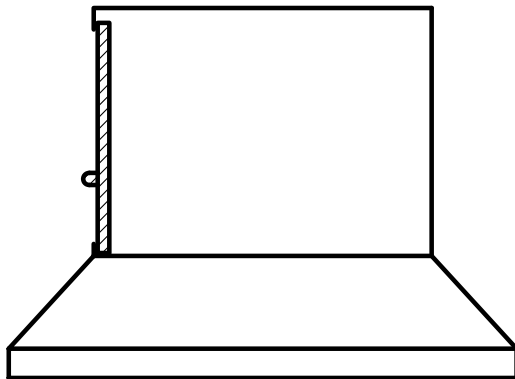

## 4-02.03. Filter Access Panel Installation

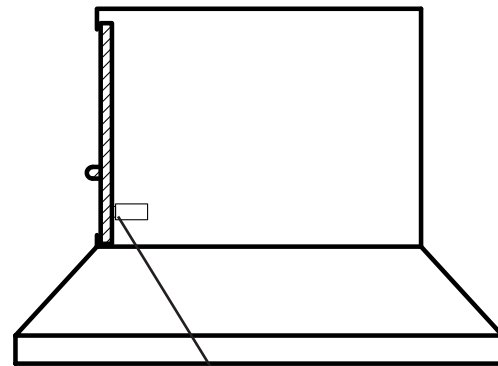
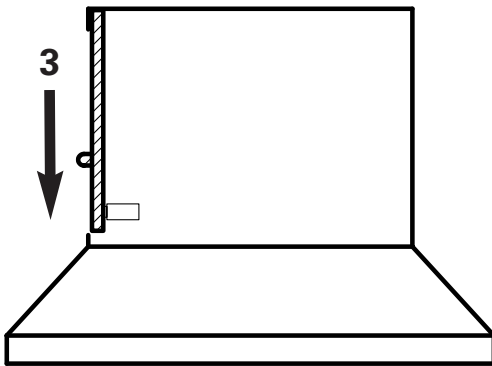
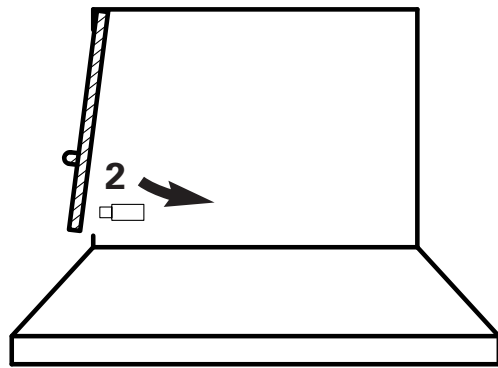
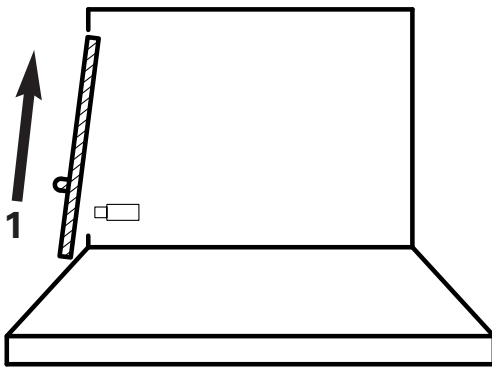

Switch plunger must be actuated by the Access Panel

## 4-02.04. Baffle Filter Removal

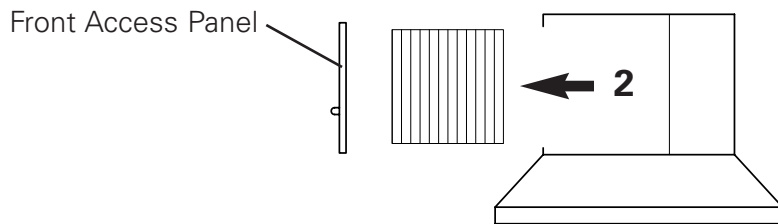
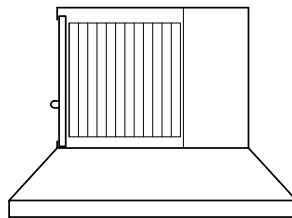

## 4-02.05. Baffle Filter Installation

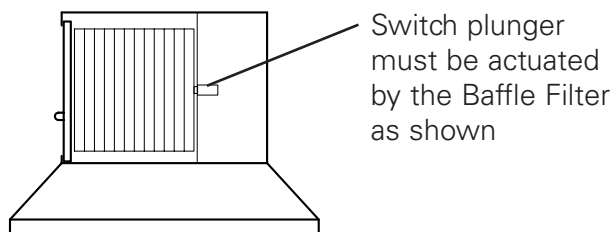
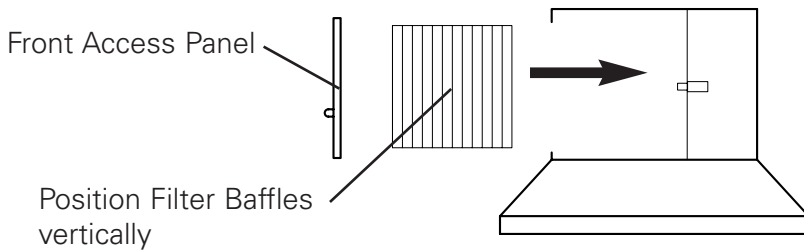

## 4-02.06. Baffle Filter Missing

If the Baffle Filter is missing or not in place correctly the Filter Missing Light **1** will illuminate. See Section 7-2.05 Baffle Filter Installation.

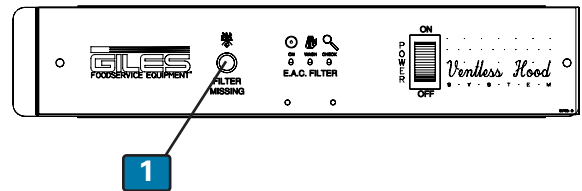

## 4-02.07. Baffle Filter Cleaning

The Baffle Filter should be cleaned daily. Place the Baffle Filter in a sink and clean with a mild non-caustic biodegradable degreaser. Dry thoroughly, then reinstall in the unit.

## 4-02.08. EAC Filter Removal

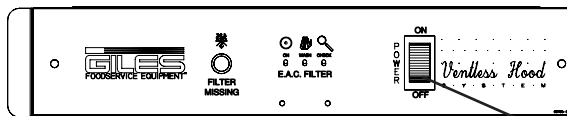

**1** Place in OFF position

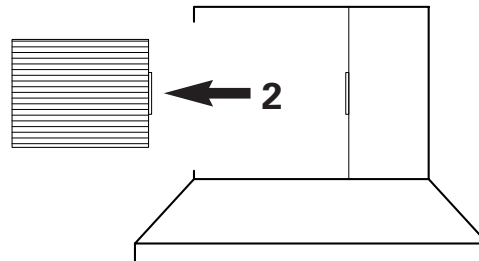
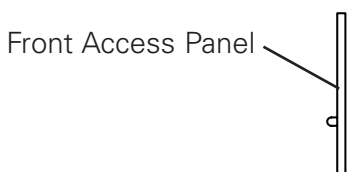
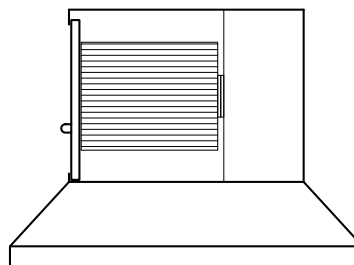

## 4-02.09. EAC Filter Installation

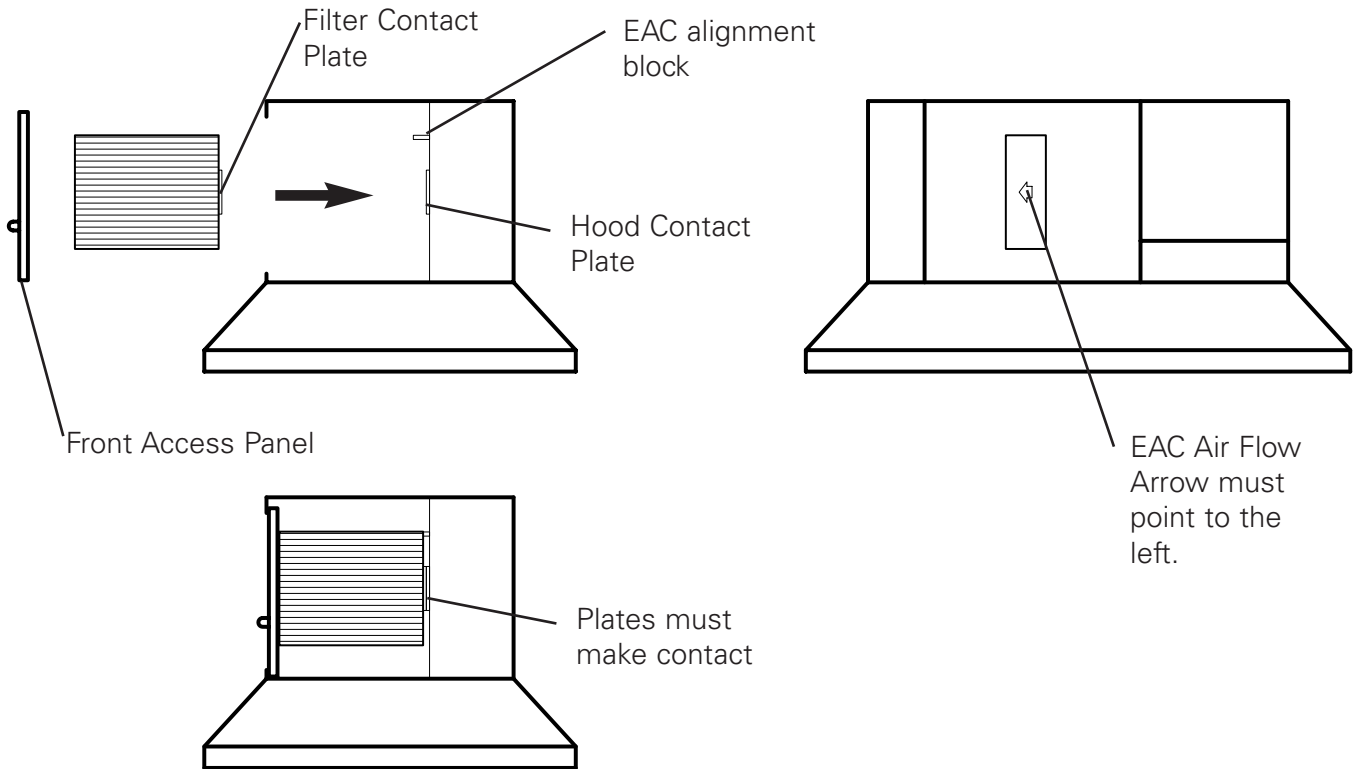

## 4-02.10. EAC Filter Status

The three indicator lights on the Control Panel display the status of the EAC Filter.

- 1** ON The EAC Filter is in place and powered.
- 2** WASH The EAC Filter is becoming excessively dirty and must be cleaned. If this light is on for more than 2 minutes an intermittent alarm will sound, (if the hood is interlocked with the Appliance below the hood, then the Appliance will turn off).
- 3** CHECK The EAC Filter is not operating. Either the filter is not getting a proper electrical connection or it is damaged. If this light is on for more than 2 minutes an intermittent alarm will sound, (if the hood is interlocked with the Appliance below the Hood, then the Appliance will turn off).

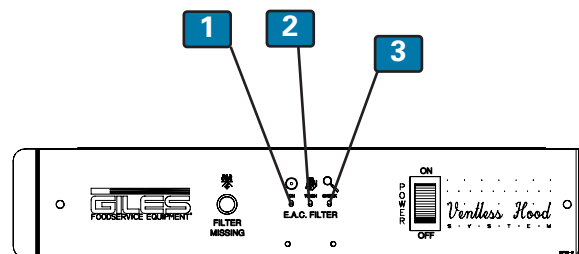



## 4-02.11. EAC Filter Cleaning

The EAC Filter should be cleaned daily.

### CAUTION

- Do not bend the fins or break the ionizer wires on the EAC as this will prevent the EAC from working properly and potentially void the warranty.

1. Mix a mild non-caustic biodegradable degreaser, such as Simple Green or Clean Magic, with 6.5 gallons of water in the included Soak Tank **1**.
2. Holding the contact plate **2** on the EAC **3** slowly lower the filter into the Soak Tank.
3. After allowing the EAC to soak for 20 to 30 minutes, using the contact plate **2**, lift the EAC up and down approximately 1" to 2" to help remove the grease residue.
4. Slowly remove the EAC from the tank and rinse clean in a sink using hot water.
5. Allow the EAC to air dry, thoroughly.

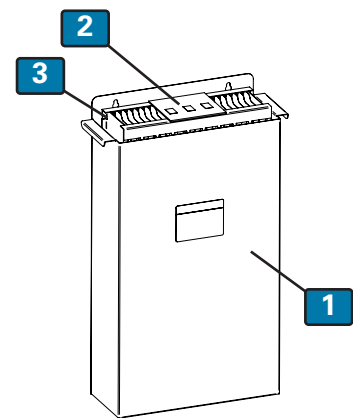

### CAUTION

- Do not dry the EAC either by running the hood to air dry or by running the appliance to heat dry. This could potentially damage the EAC causing improper operation and voiding the warranty.

## 4-02.12. Charcoal Filter Removal



**1** Place in OFF position

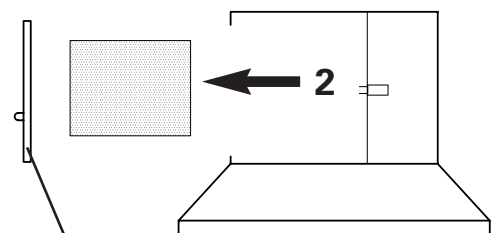
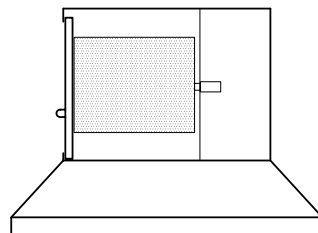

Front Access Panel

## 4-02.13. Charcoal Filter Installation

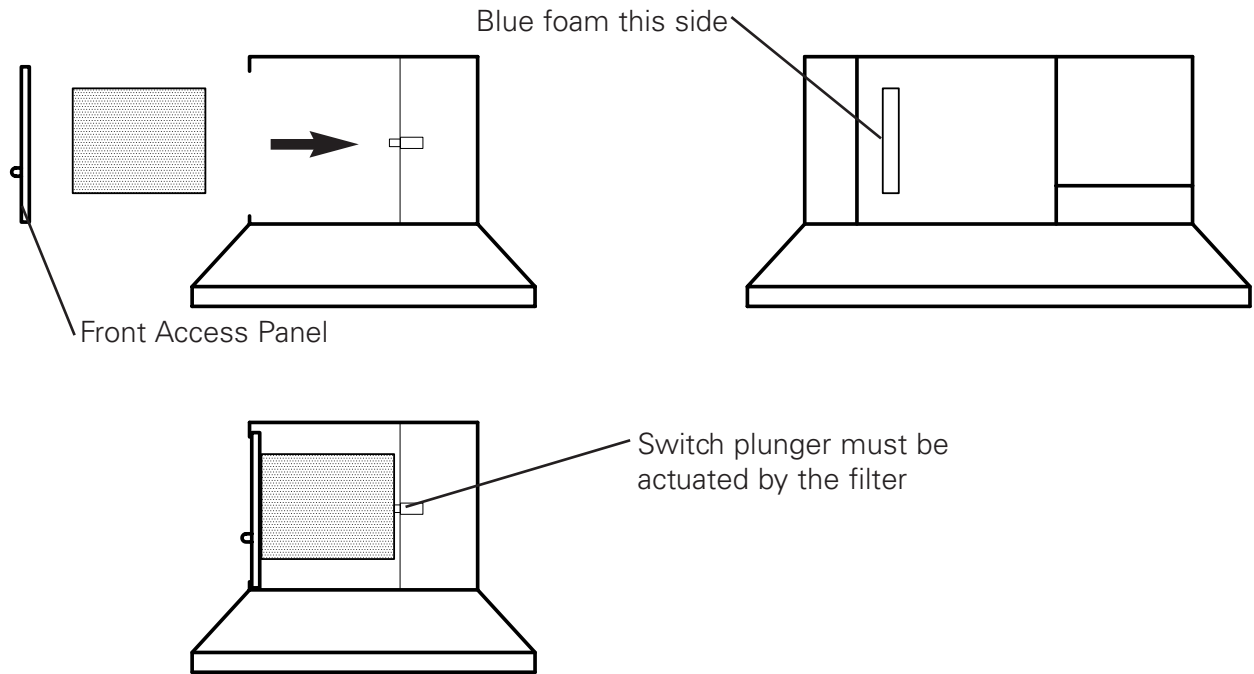

## 4-02.14. Charcoal Filter Missing

If the Charcoal Filter is missing or not in place correctly and the unit is on, the Filter Missing Light **1** will illuminate. See Section 7-2.13 Charcoal Filter Installation.

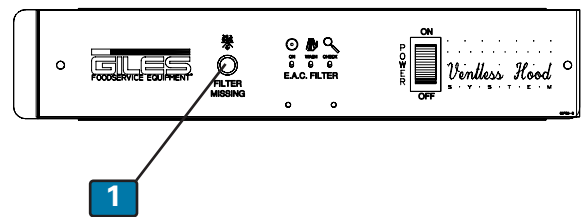

## 4-02.15. Charcoal Filter Replacement

### **WARNING**

- **NEVER attempt to clean and reuse the Charcoal Filter. This could cause damage to the unit.**

Replace the Charcoal Filter every 30 days. Use Replacement Part No. 31964 (PO-VH) or 31963 (OVH-10).

## 4-03. Filter Alarm Chart

Alarm Sound	What will happen	Filter effected	Cause	Solution	See Section
Continuous beep	Alarm will sound and the power to the appliance will shut off. (If ILS, the power to the appliance and hood with shut off)	Charcoal	Filter dirty	Replace Filter	7-2.12. and 7-2.13.
Continuous beep	Alarm will sound and the power to the appliance will shut off. (If ILS, the power to the appliance and hood with shut off)	Baffle	Filter dirty	Clean Filter	7-2.07.
Intermittent beeping	Alarm will sound for 2 minutes then power to the appliance will shut off. (If ILS, the power to the appliance and hood with shut off)	E.A.C.	Filter dirty	Clean Filter	7-2.11.



**Notes:**

## 5. Hood Cleaning and Maintenance

This section describes the cleaning of the hood. The hood must be cleaned every 3 months.

### 5-01. Hood Cleaning

**Interior** -Disconnect power to the unit. Remove the Filter Cover and all Filters from the hood. Using a soft cloth, sponge or towel and a mild non-caustic biodegradable degreaser, clean the entire Hood Plenum area and Filter Channels.

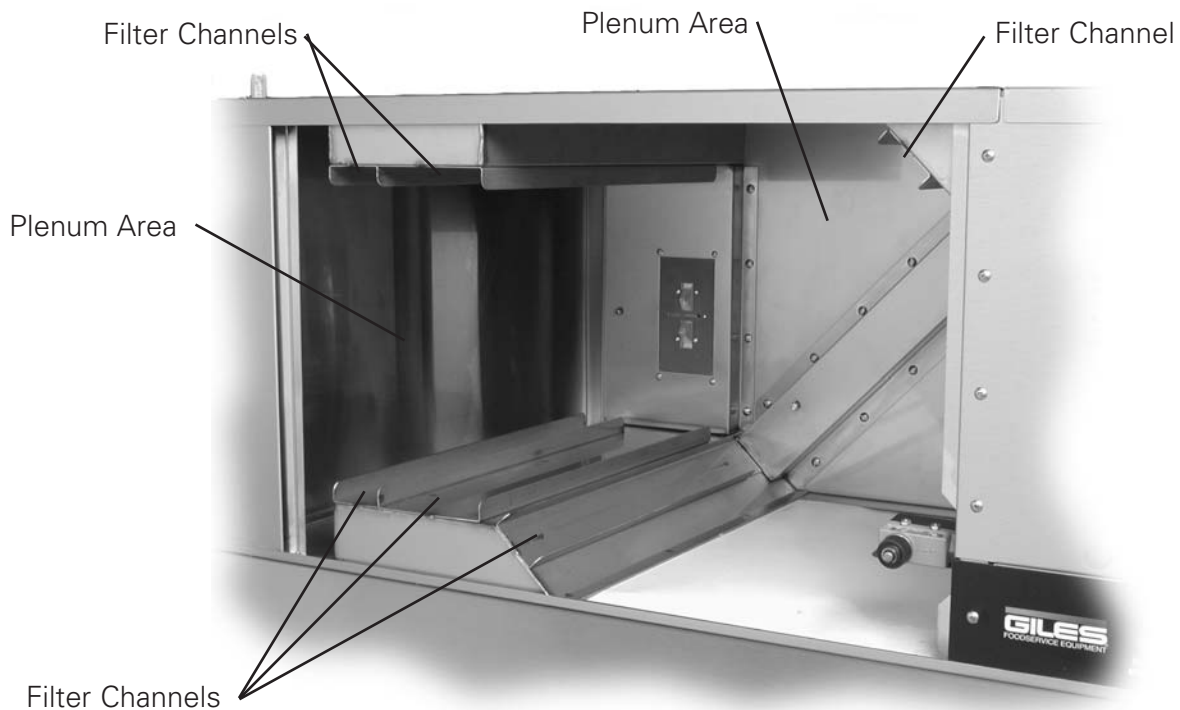

**Exterior** -remove power from the unit. Using a stainless steel cleaner, clean all external stainless steel parts.

**Filters** -To clean and replace Filters, see Section 4.02.01 Ventless Hood Filter Table.

## 5-02. Fan Lubrication (OVH-10 Only)

This procedure is to be performed every 6 months.

1. Disconnect Power to the Hood and the Appliance under the hood.
2. Remove the Filter Cover.
3. Remove the Fan Cover.
4. Remove the Right Top Hood Cover.
5. Locate the Fan and the Oil Ports shown below.
6. Using a 20 Weight, Non-Detergent Oil, add 10 to 12 drops in each Oil Port.
7. Reinstall Right Top Hood Cover, then the Fan Cover, then the Filter Cover.
8. Reconnect Power to Hood and Appliance under the Hood.



20 Weight Oil.  
10 to 12 drops  
per Oil Port

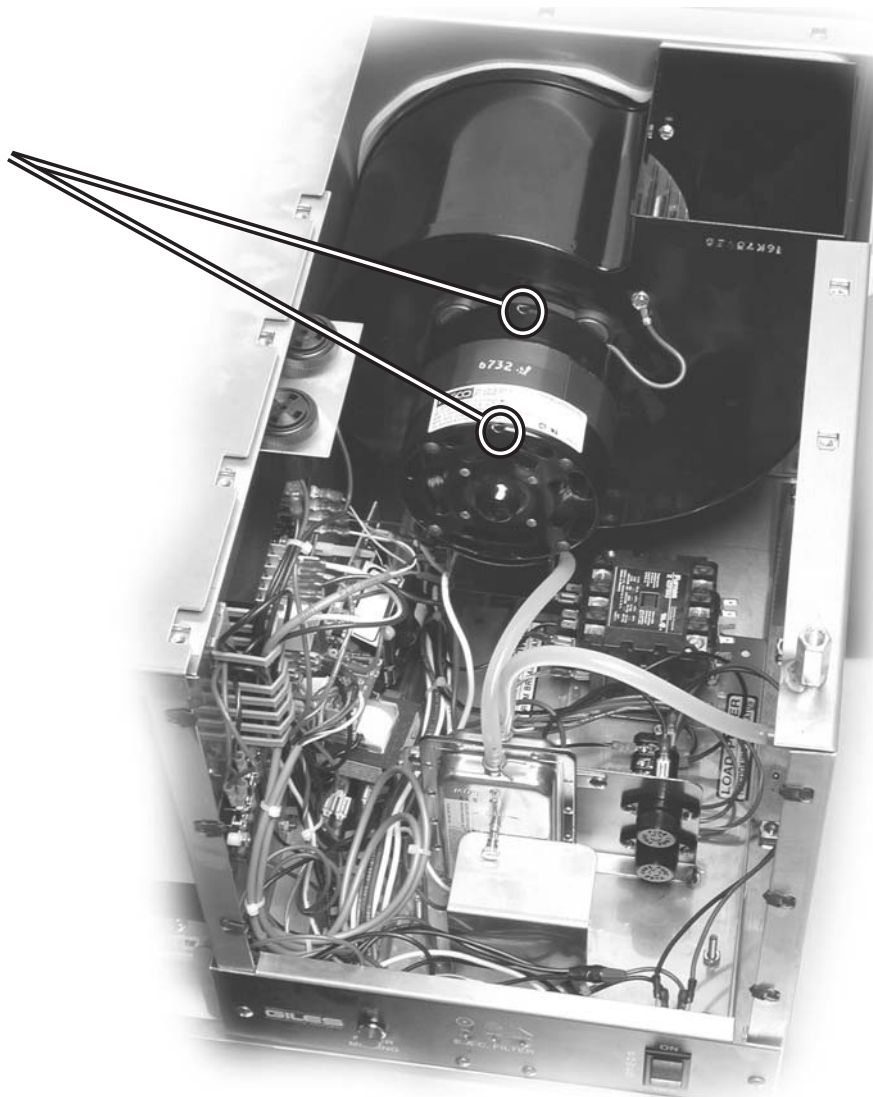

## 6. Troubleshooting

This section describes troubleshooting procedures for the PO-VH and OVH-10. Refer to the wiring diagrams in Section 8 for more detailed analysis.

### DANGER

- Electrical troubleshooting procedures should be done **ONLY** by qualified service personnel. Death or serious injury will result from contact with energized electrical components.
- Failure to comply with these **DANGER** notices will result in death or serious injury, equipment/property damage, and void the warranty.

### 6-1. Troubleshooting Procedures

Problem	Probable Cause	Repair Procedure
<b>Hood will not turn on</b>	a. (ILS only) "HOLD START" button not held for 5 seconds	a. Hold down "HOLD START"
	b. Power switch bad	b. Replace power switch.
	c. Improper supply Voltage	c. Connect to proper voltage source.
	d. Hood cover not closed	d. Close hood cover.
	e. Not connected to power source	e. Connect to proper power source.
	f. Bad fuse or circuit breaker	f. Check the fuse or breaker.
<b>Filter Missing Light on</b> • Initial Start-up Only	a. Baffle filter is not installed	a. Install Baffle filter.
	b. Charcoal filter is not installed	b. Install charcoal filter.
<b>Check or Wash Light on</b>	a. EAC shorted	a. Replace or repair EAC.
	b. EAC dirty	b. Clean EAC.
	c. High voltage power supply faulty.	c. Replace high voltage power supply
	d. High voltage wires shorted.	d. Correct shorted condition.
	e. Bad contact plate	e. Replace contact plate.

**6-1. Troubleshooting Procedures (Cont'd.)**

<b>Problem</b>	<b>Probable Cause</b>	<b>Repair Procedure</b>
<b>Appliance will not heat</b> <ul style="list-style-type: none"> <li>• Hood power on</li> <li>• Filter missing light on</li> </ul>	a. Baffle Filter missing	a. Install Baffle Filter
	b. Baffle Filter not installed properly	b. Reinstall Baffle Filter
	c. Charcoal Filter missing	c. Install Charcoal Filter
<b>Appliance will not heat</b> <ul style="list-style-type: none"> <li>• Hood power on</li> <li>• Filter missing light off</li> <li>• Buzzer emitting a continuous tone</li> </ul>	a. Charcoal Filter clogged	a. Replace Charcoal Filter
	b. Baffle Filter clogged	b. Clean Baffle Filter
	c. Clogged filter switch out of adjustment	c. Adjust clogged switch only. (initial start-up switch bad)
	d. Kinked vacuum line	d. Remove vacuum line kinks
	e. Fan running slow	e. Check voltage
<b>Appliance will not heat</b> <ul style="list-style-type: none"> <li>• Hood power on</li> <li>• Buzzer emitting a pulsating tone</li> </ul>	a. EAC shorted	a. Repair EAC
	b. EAC dirty	b. Clean EAC
	c. EAC power supply faulty	c. Replace EAC power supply
	d. EAC wires shorted	d. Check voltage
	e. Bad contact plate	e. Replace contact plate
	f. EAC module faulty	f. Replace EAC module
	g. EAC ionizer wire broken or missing	g. Replace ionizer wire



## 7. Parts List

This section lists various parts that are available for replacement on the PO-VH and OVH-10.

### 7-1. Parts Ordering and Service Information

If you require assistance or need repairs, please contact your area developer for a service agency in your area. For further assistance, please contact the Giles Enterprises, Inc. factory at the following phone numbers:

#### IN THE UNITED STATES, CANADA or MEXICO

Please call 1-800-288-1555 during normal business hours, 8:00AM-5:00PM Central Time Zone; for Emergency Equipment Repair Service, after normal business hours call 1-800-288-1555, extension 314.

#### IN ALL OTHER COUNTRIES

Please call 1-334-272-3528 during normal business hours, 8:00AM-5:00PM Central Time Zone; for Emergency Equipment Repair Service, after normal business hours call 1-334-272-3528 extension 314.

#### INTERNET

Please visit our website on the world wide web at: [www.gilesent.com](http://www.gilesent.com).

The goal of the Giles team of professionals is to provide you with the highest quality of service and assistance. You can help us accomplish this by obtaining the following information and having it readily available when calling. The information is recorded on the Serial Plate attached to the side of the unit.



The area below may be helpful in recording information for use as a quick reference.

**Model Number:** \_\_\_\_\_

**Serial Number:** \_\_\_\_\_

**Phase:** \_\_\_\_\_

**Voltage:** \_\_\_\_\_

**Nature of Problem:** \_\_\_\_\_

7-2. Fan Compartment -PO-VH

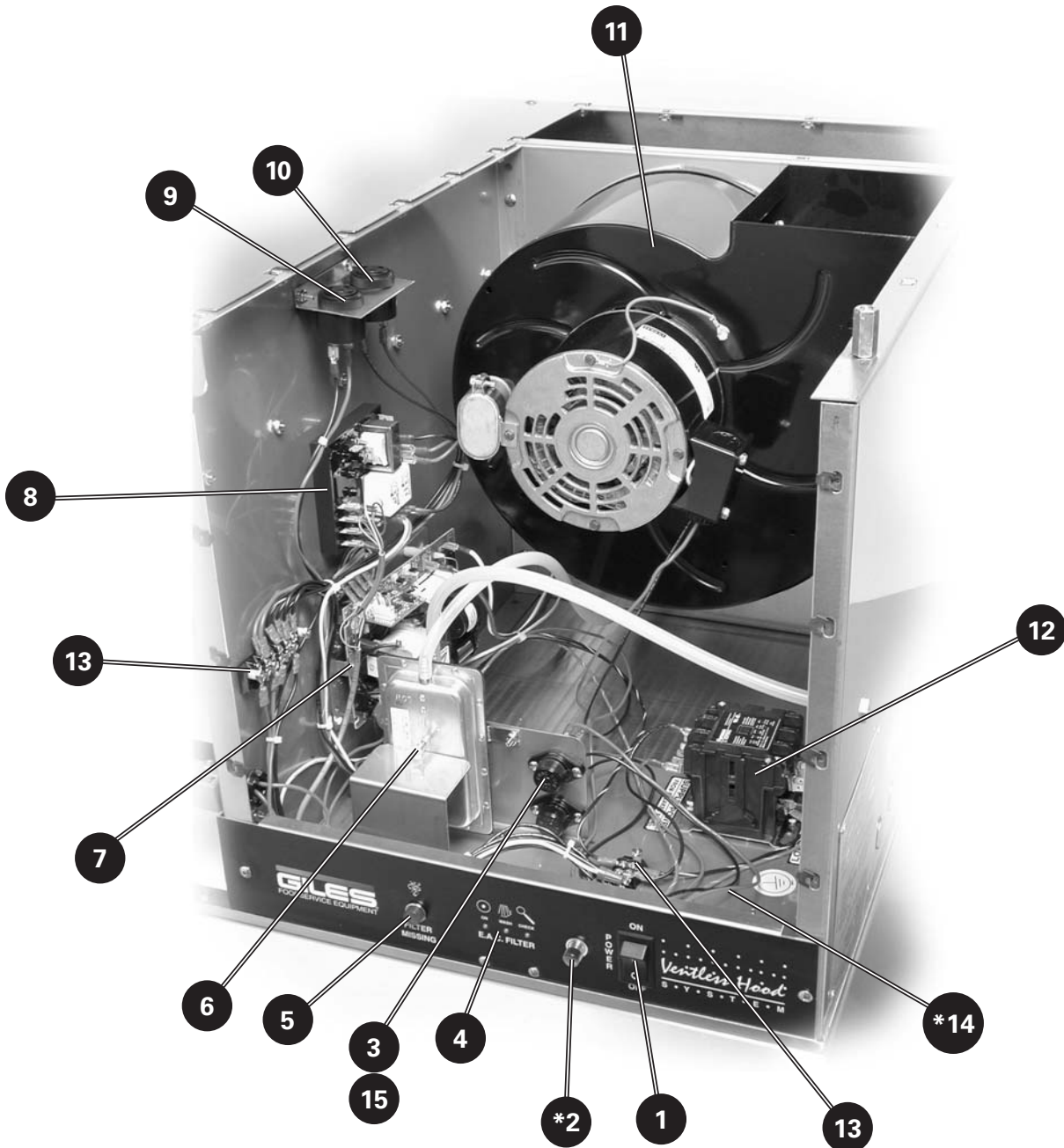

\* -Not shown



## 7-2. Parts List for Fan Compartment -PO-VH

Item	Part No.	Qty.	Description
1	21190	1	SWITCH, ROCKER, ON-OFF, 250V, 20A, DPST
*2	23173	1	SWITCH,PUSHBUTTON,N.O.,MOM,PLUNGER
3	21950	2	HOLDER, FUSE, 300V, 15A, SC 0 TO 15
4	24209	1	LED, AIR FILTER, EAC
5	22300	1	LIGHT, PILOT, 250V, ROUND, RED
6	23001	1	SWITCH, VACUUM, HOSE BARB
7	24208	1	POWER SUPPLY, W/DRIVER BRD, 208-240V,EAC
8	23776	1	MODULE, AIR FILTER, ALARM AND SHUTDOWN
9	23782	1	SONALERT, 250V, CONTINUOUS BEEP
10	22950	1	SONALERT, 250V, INTERMITTENT
11	35864	1	FAN, ASSY, 208-240V/60/1
12	32208	1	CONTACTOR,ASSY,208/240VAC,3 POLE
13	23751	1	TERMINAL BLOCK, MA106,6 POLE
*14	21191	1	RELAY, 30A, 208V, 2 POLE, USED IN PUSH TO START ONLY
*14	21174	1	RELAY, 30A, 240V, 2 POLE, USED IN PUSH TO START ONLY
15	21875	2	FUSE, 6AMP, SC-6

\* -Not shown



7-3. Filter Compartment -PO-VH

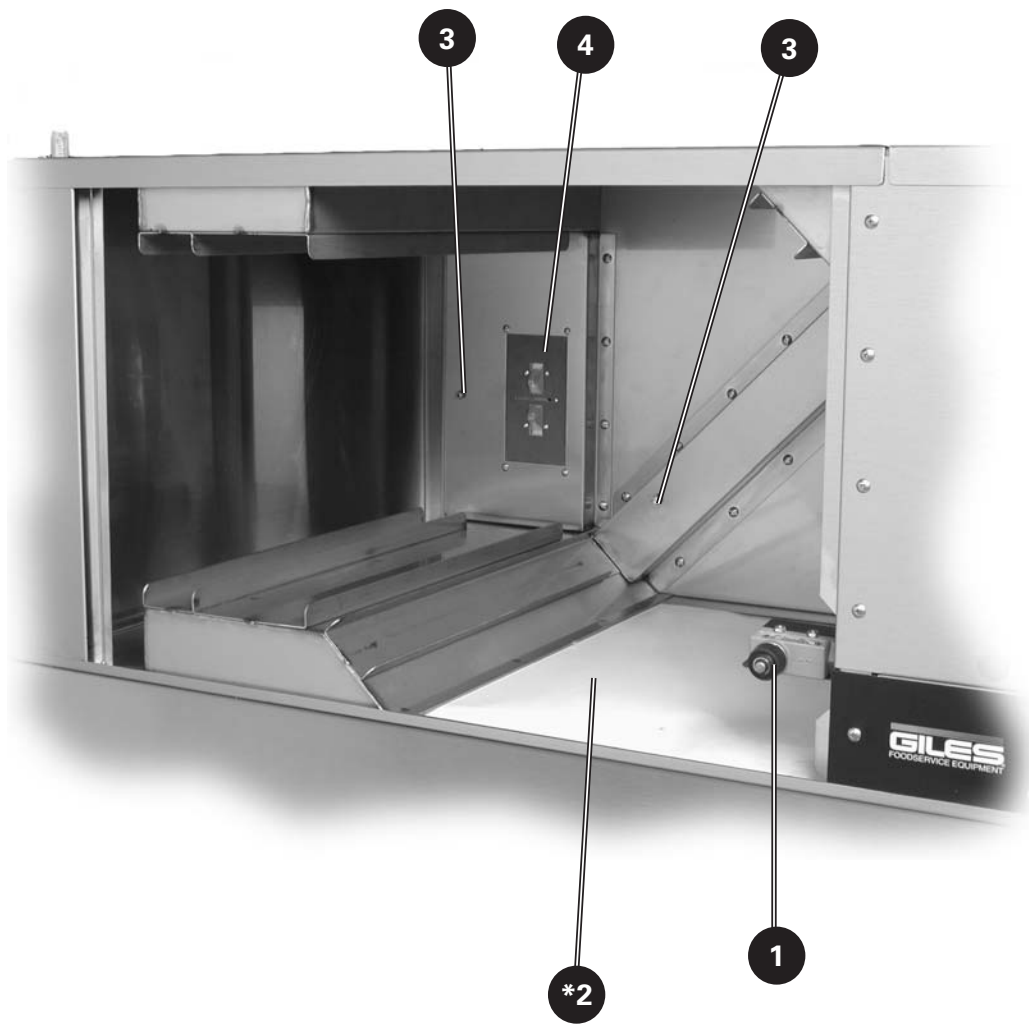

\* -Not shown



## 7-3. Parts List for Filter Compartment -PO-VH

Item	Part No.	Qty.	Description
1	21157	1	SWITCH, LIMIT, 15A, 250V DRAIN SWITCH
*2	30327	1	PANEL, UPPER STRUCTURE, FILTER ACCESS
3	24237	2	SWITCH, PLUNGER, 250V, 15A
4	21125	1	BOARD, CONTACT, EAC, VH UNITS

\* -Not shown

7-4. Fan Compartment -OVH-10

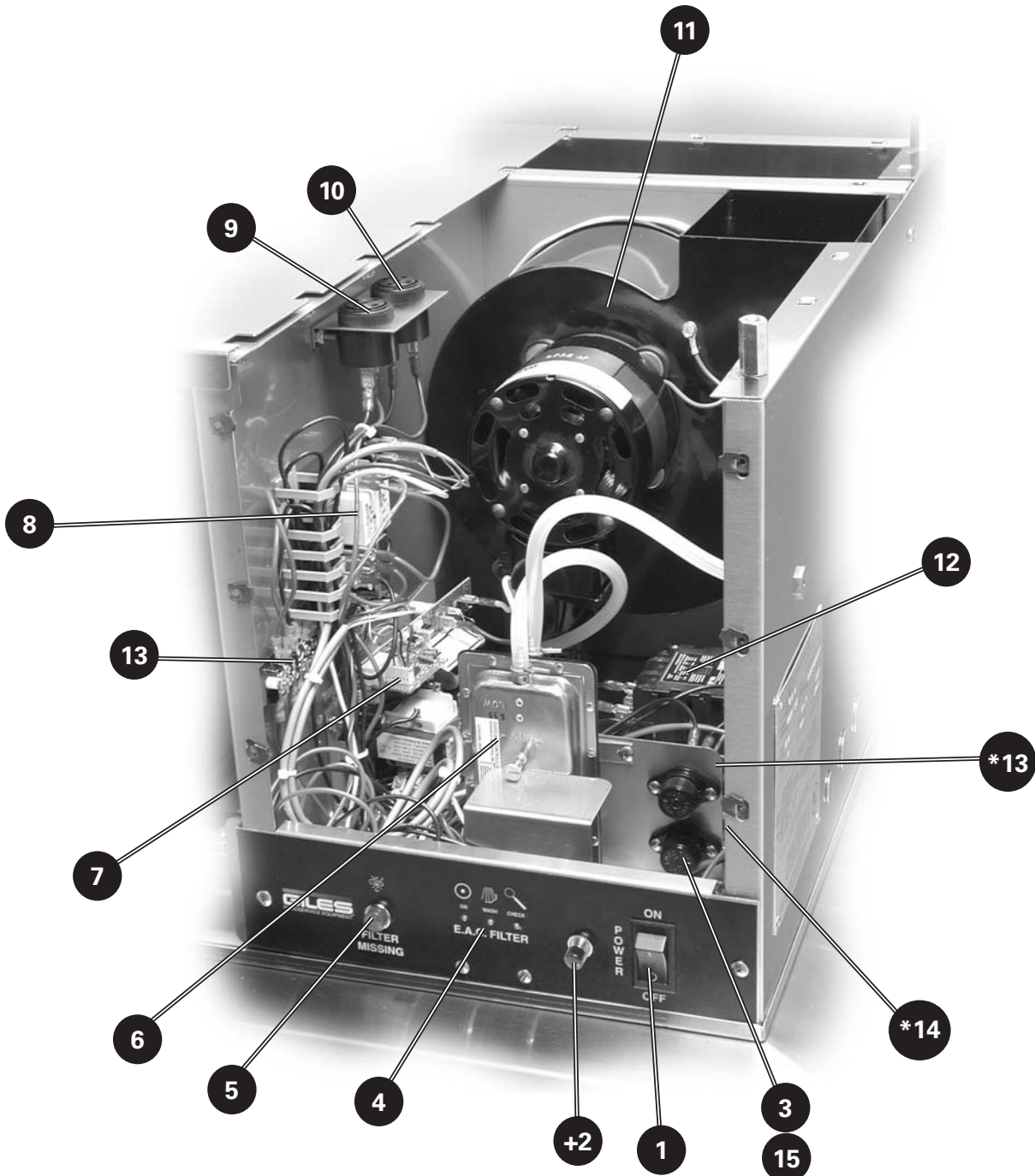

+ -ILS Only  
\* -Not shown

## 7-4. Parts List for Fan Compartment -OVH-10

Item	Part No.	Qty.	Description
1	21190	1	SWITCH, ROCKER, ON-OFF, 250V, 20A, DPST
+2	23173	1	SWITCH,PUSHBUTTON,N.O.,MOM,PLUNGER
3	21950	2	HOLDER, FUSE, 300V, 15A, SC 0 TO 15
4	24209	1	LED, AIR FILTER, EAC
5	22300	1	LIGHT, PILOT, 250V, ROUND, RED
6	23001	1	SWITCH, VACUUM, HOSE BARB
7	24208	1	POWER SUPPLY, W/DRIVER BRD, 208-240V,EAC
8	23776	1	MODULE, AIR FILTER, ALARM AND SHUTDOWN
9	23782	1	SONALERT, 250V, CONTINUOUS BEEP
10	22950	1	SONALERT, 250V, INTERMITTENT
11	35881	1	FAN, ASSY, 208-240V/60/1
12	32208	1	CONTACTOR,ASSY,208/240VAC,3 POLE
13	23751	1	TERMINAL BLOCK, MA106,6 POLE
* 14	21191	1	RELAY, 30A, 208V, 2 POLE
* 14	21174	1	RELAY, 30A, 240V, 2 POLE
15	21875	2	FUSE, 6AMP, SC-6

+ -ILS Only  
 \* -Not shown

7-5. Filter Compartment -OVH-10

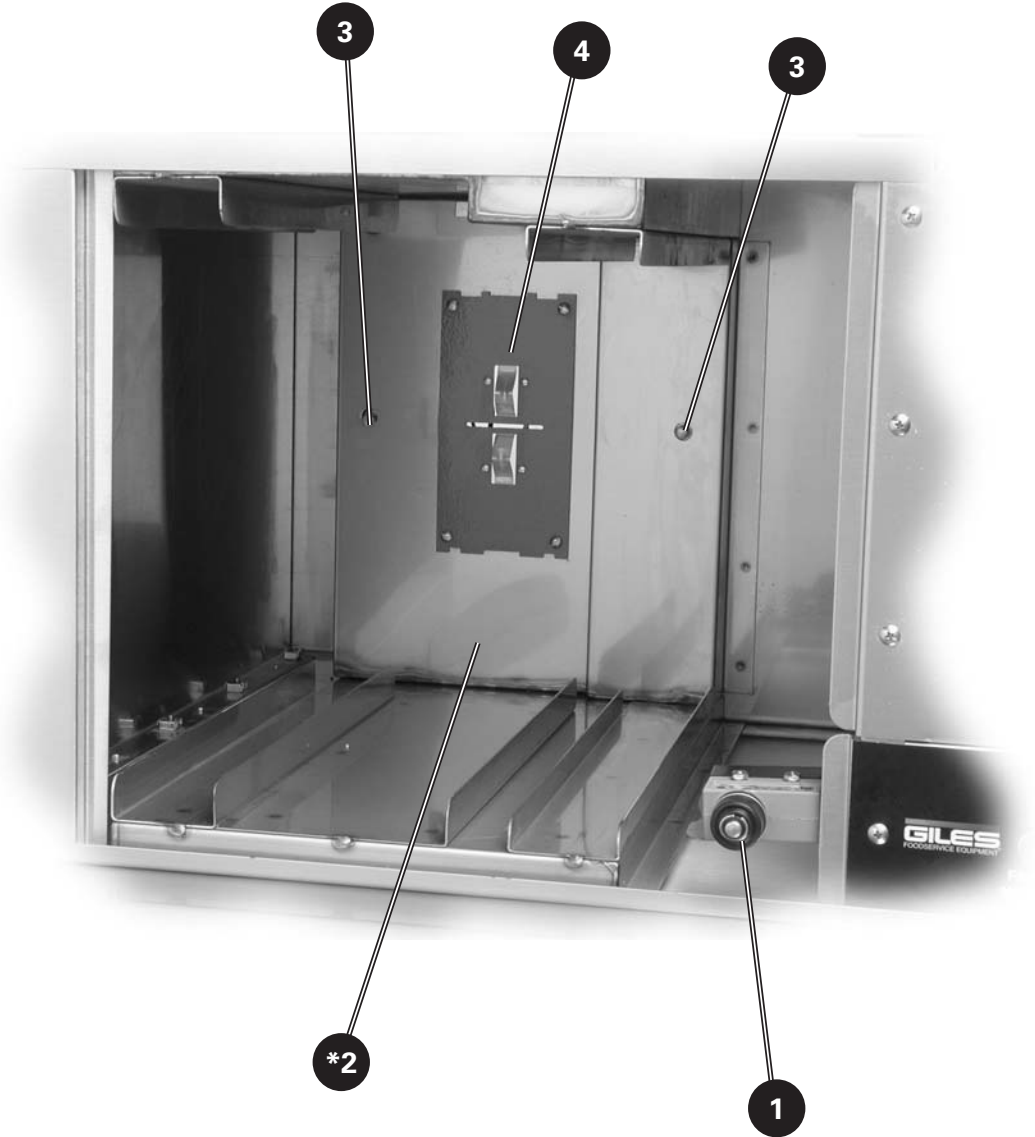

\* -Not shown





## 7-5. Parts List for Filter Compartment -OVH-10

Item	Part No.	Qty.	Description
1	21157	1	SWITCH, LIMIT, 15A, 250V DRAIN SWITCH
*2	30327	1	PANEL, UPPER STRUCTURE, FILTER ACCESS
3	24237	2	SWITCH, PLUNGER, 250V, 15A
4	21125	1	BOARD, CONTACT, EAC, VH UNITS

\* -Not shown



**Notes:**

## 8. Wiring Diagram

The following section contains various Wiring Diagrams for the PO-VH and OVH-10 units. Please check the Serial Plate, as shown below, for the unit's Model Name, Voltage, Hertz, and Phase.

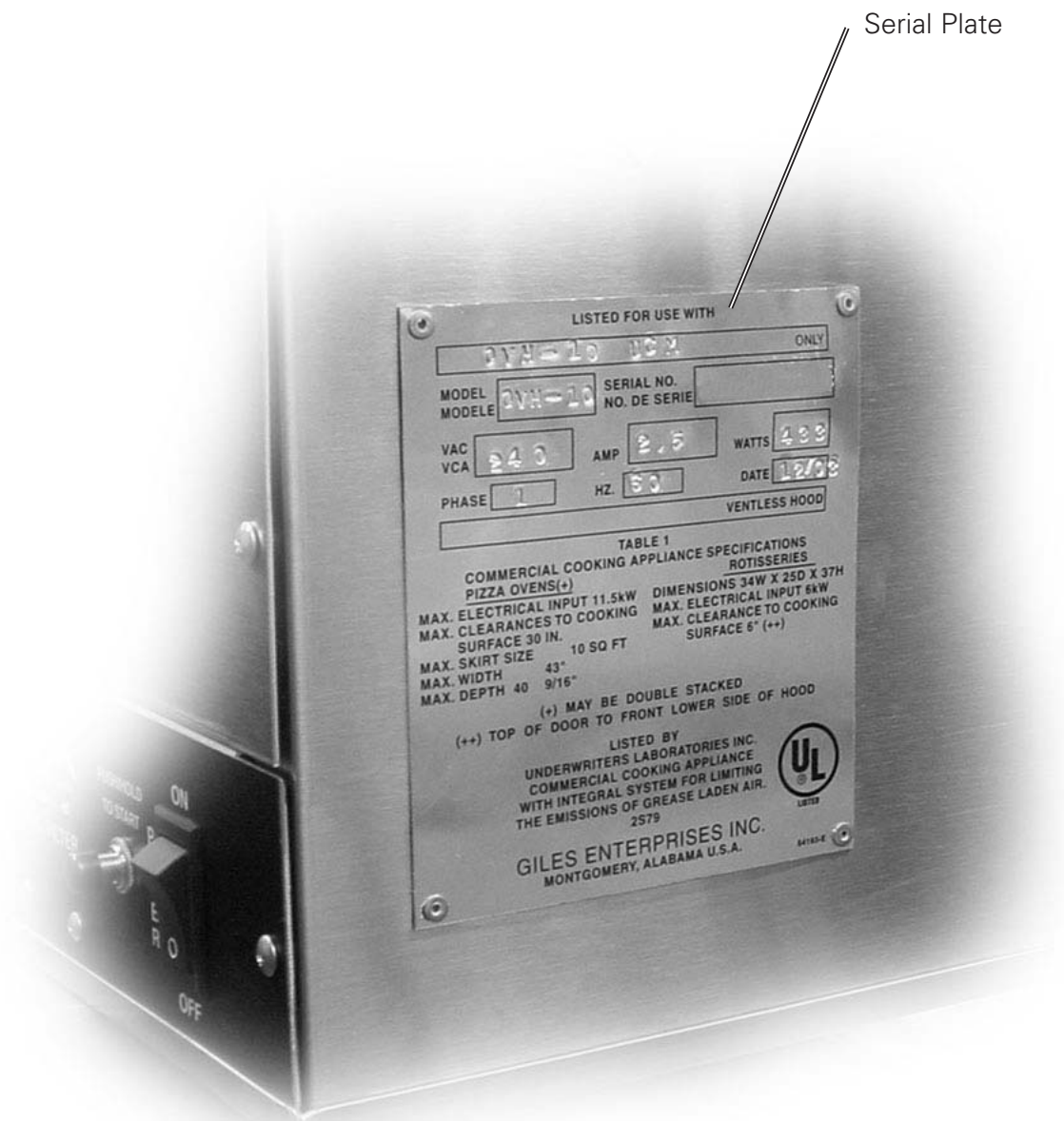

## 8-01. Wiring Diagram OVH-10 208-240/60/1

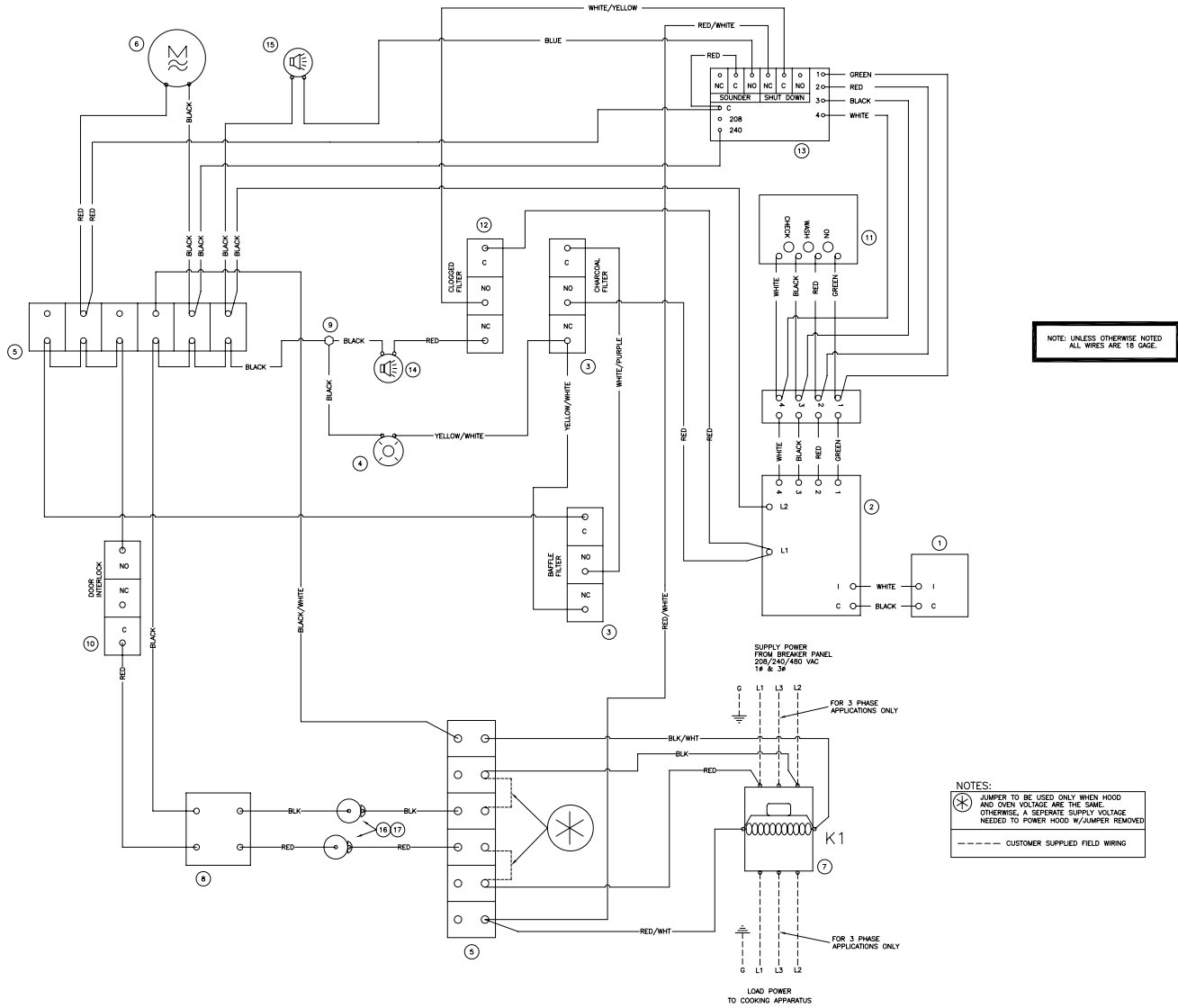

WIRING DIAGRAM OVH-10 208-240/60/1 W/INTERLOCK RELAY  
 INTERLOCKING RELAY FOR AUXILIARY MACHINE CONTROL

32804-G  
 12-02-99

WIRING DIAGRAM P/N:  
 32804-G

## 8-01. Parts List for Wiring Diagram OVH-10 208-240/60/1

Item	Part No.	Qty.	Description
01	21125	1	BOARD, CONTACT, EAC, VH UNITS
02	24208	1	POWER SUPPLY, W/DRIVER BRD, 208-240V,EAC
03	24237	2	SWITCH, PLUNGER, 250V, 15A
04	22300	1	LIGHT, PILOT, 250V, ROUND, RED
05	23751	2	TERMINAL BLOCK, MA106,6 POLE
06	35881	1	FAN, ASSY, 208-240/60/1
07	32208	1	CONTACTOR,ASSY,208/240VAC,3 POLE
08	21190	1	SWITCH, ROCKER, ON-OFF, 250V, 20A, DPST
09	25275	1	WIRENUT, IDEAL BLUE
10	21157	1	SWITCH, LIMIT, 15A, 250V DRAIN SWITCH
11	24209	1	LED, AIR FILTER, EAC
12	23001	1	SWITCH, VACUUM, HOSE BARB
13	23776	1	MODULE, AIR FILTER, ALARM AND SHUTDOWN
14	23782	1	SONALERT, 250V, CONTINUOUS BEEP
15	22950	1	SONALERT, 250V, INTERMITTENT
16	21950	2	HOLDER, FUSE, 300V, 15A, SC 0 TO 15
17	21875	2	FUSE, 6AMP, SC-6

## 8-02. Wiring Diagram OVH-10 208-240/60/1 (ILS)

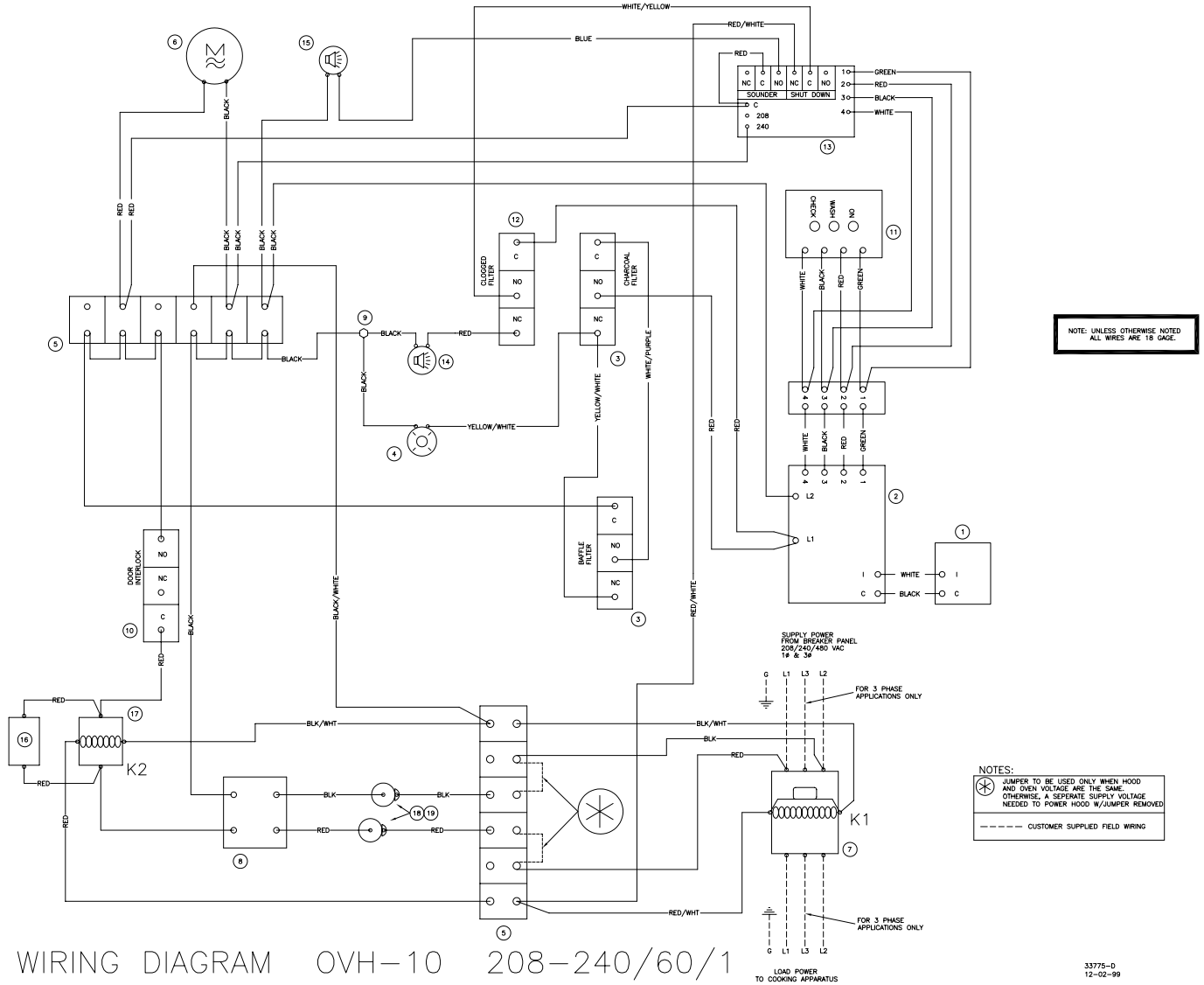

## 8-02. Parts List for Wiring Diagram OVH-10 208-240/60/1 (ILS)

Item	Part No.	Qty.	Description
01	21125	1	BOARD, CONTACT, EAC, VH UNITS
02	24208	1	POWER SUPPLY, W/DRIVER BRD, 208-240V,EAC
03	24237	2	SWITCH, PLUNGER, 250V, 15A
04	22300	1	LIGHT, PILOT, 250V, ROUND, RED
05	23751	2	TERMINAL BLOCK, MA106,6 POLE
06	35881	1	FAN, ASSY, 208-240/60/1
07	32208	1	CONTACTOR,ASSY,208/240VAC,3 POLE
08	21190	1	SWITCH, ROCKER, ON-OFF, 250V, 20A, DPST
09	25275	1	WIRENUT, IDEAL BLUE
10	21157	1	SWITCH, LIMIT, 15A, 250V DRAIN SWITCH
11	24209	1	LED, AIR FILTER, EAC
12	23001	1	SWITCH, VACUUM, HOSE BARB
13	23776	1	MODULE, AIR FILTER, ALARM AND SHUTDOWN
14	23782	1	SONALERT, 250V, CONTINUOUS BEEP
15	22950	1	SONALERT, 250V, INTERMITTENT
16	23173	1	SWITCH,PUSHBUTTON,N.O.,MOM,PLUNGER
17	21191	1	RELAY, 30A, 208V, 2 POLE
17	21174	1	RELAY, 30A, 240V, 2 POLE
18	21950	2	HOLDER, FUSE, 300V, 15A, SC 0 TO 15
19	21875	2	FUSE, 6AMP, SC-6

## 8-03. Wiring Diagram PO-VH 208-240/60/1

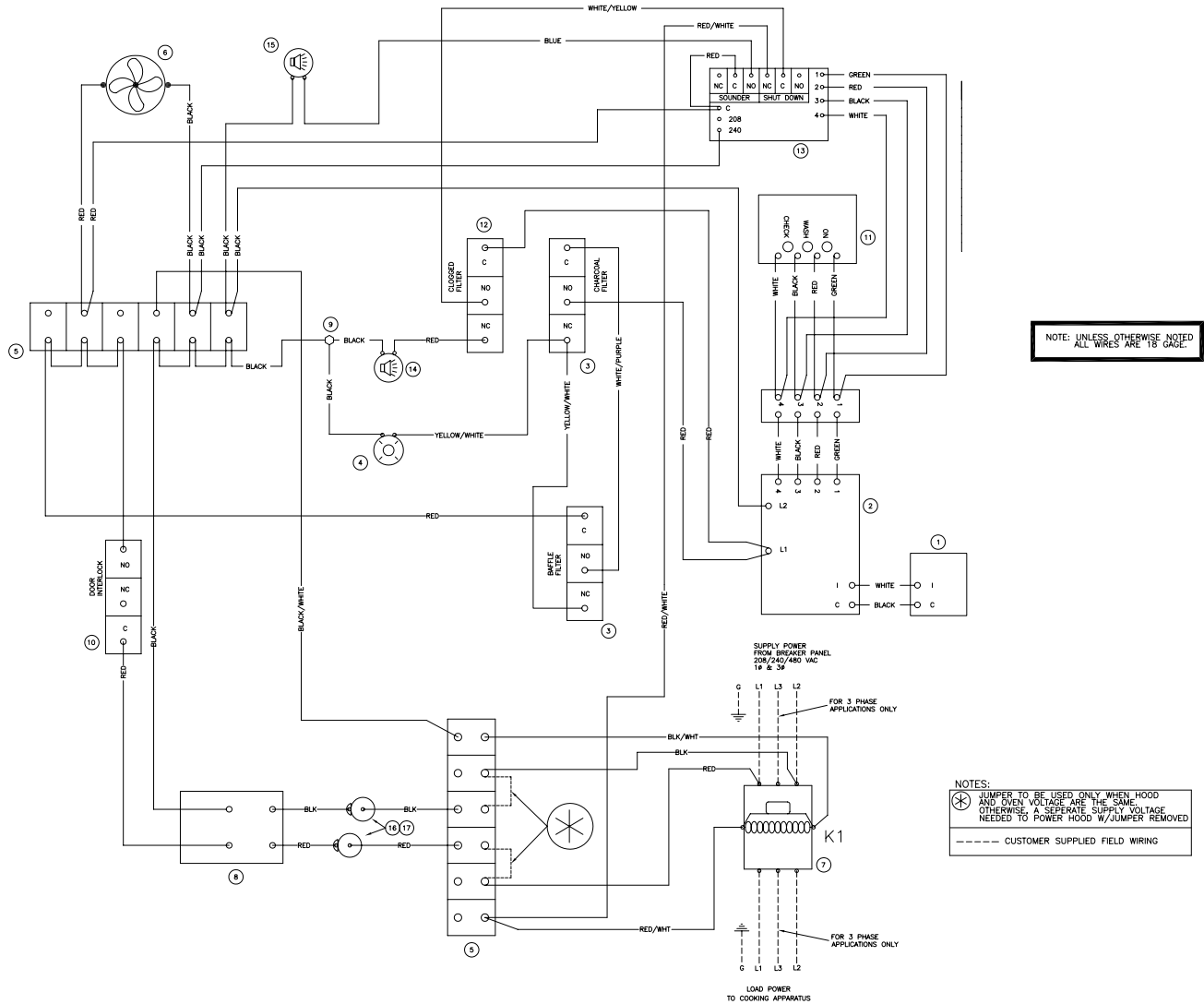

WIRING DIAGRAM PO-VH W/INTERLOCKS 208-240/60/1  
INTERLOCKING RELAY FOR AUXILIARY MACHINE CONTROL

35348-C  
7-10-01

WIRING DIAGRAM P/N:  
35348-C



## 8-03. Parts List for Wiring Diagram PO-VH 208-240/60/1

Item	Part No.	Qty.	Description
01	21125	1	BOARD, CONTACT, EAC, VH UNITS
02	24208	1	POWER SUPPLY, W/DRIVER BRD, 208-240V,EAC
03	24237	2	SWITCH, PLUNGER, 250V, 15A
04	22300	1	LIGHT, PILOT, 250V, ROUND, RED
05	23751	2	TERMINAL BLOCK, MA106,6 POLE
06	35864	1	FAN, ASSY, 208-240V/60/1
07	32208	1	CONTACTOR,ASSY,208/240VAC,3 POLE
08	21190	1	SWITCH, ROCKER, ON-OFF, 250V, 20A, DPST
09	25275	1	WIRENUT, IDEAL BLUE
10	21157	1	SWITCH, LIMIT, 15A, 250V DRAIN SWITCH
11	24209	1	LED, AIR FILTER, EAC
12	23001	1	SWITCH, VACUUM, HOSE BARB
13	23776	1	MODULE, AIR FILTER, ALARM AND SHUTDOWN
14	23782	1	SONALERT, 250V, CONTINUOUS BEEP
15	22950	1	SONALERT, 250V, INTERMITTENT
16	21950	2	HOLDER, FUSE, 300V, 15A, SC 0 TO 15
17	21875	2	FUSE, 6AMP, SC-6



## 8-04. Parts List for Wiring Diagram PO-VH 208-240/60/1 (ILS)

Item	Part No.	Qty.	Description
01	21125	1	BOARD, CONTACT, EAC, VH UNITS
02	24208	1	POWER SUPPLY, W/DRIVER BRD, 208-240V,EAC
03	24237	2	SWITCH, PLUNGER, 250V, 15A
04	22300	1	LIGHT, PILOT, 250V, ROUND, RED
05	23751	2	TERMINAL BLOCK, MA106,6 POLE
06	35864	1	FAN, ASSY, 208-240V/60/1
07	32208	1	CONTACTOR,ASSY,208/240VAC,3 POLE
08	21190	1	SWITCH, ROCKER, ON-OFF, 250V, 20A, DPST
09	25275	1	WIRENUT, IDEAL BLUE
10	21157	1	SWITCH, LIMIT, 15A, 250V DRAIN SWITCH
11	24209	1	LED, AIR FILTER, EAC
12	23001	1	SWITCH, VACUUM, HOSE BARB
13	23776	1	MODULE, AIR FILTER, ALARM AND SHUTDOWN
14	23782	1	SONALERT, 250V, CONTINUOUS BEEP
15	22950	1	SONALERT, 250V, INTERMITTENT
16	23173	1	SWITCH,PUSHBUTTON,N.O.,MOM,PLUNGER
17	21191	1	RELAY, 30A, 208V, 2 POLE
17	21174	1	RELAY, 30A, 240V, 2 POLE
18	21950	2	HOLDER, FUSE, 300V, 15A, SC 0 TO 15
19	21875	2	FUSE, 6AMP, SC-6



**Notes:**



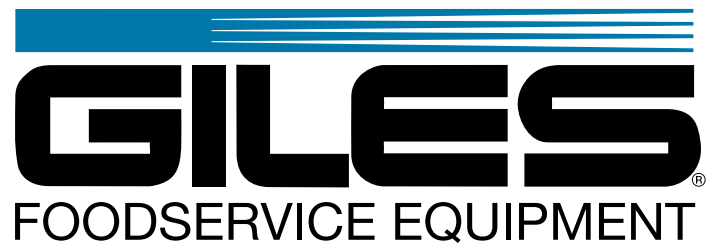

**Giles Enterprises, Inc.**

2750 Gunter Park Drive West • Montgomery, Al 36109 USA  
(334) 272-1457 • Service Hotline 1-800-554-4537 (USA & Canada Only) • FAX (334) 272-3561 • [www.gilesent.com](http://www.gilesent.com)

Form No. 60203 (Release date: 02/01)(Revision Date: 06/14/04)(Rev B)(ECO0812)(CSY)