



# Bag-In-A-Box Single/Dual Pedestal Enclosed Butter Dispenser



## Instruction Manual



Model #2396AC and #2396ADC  
Model #2396ACR and #2396ADCR







# SAFETY PRECAUTIONS

	 <b>DANGER</b>
	<p>Machine must be properly grounded to prevent electrical shock to personnel. Failure to do so could result in serious injury, or death.</p> <p>DO NOT immerse any part of this equipment in water.</p> <p>DO NOT use excessive water when cleaning.</p> <p>Keep cord and plug off the ground and away from moisture.</p> <p>Always unplug the equipment before cleaning or servicing.</p> <p>Make sure all machine switches are in the OFF position before plugging the equipment into the receptacle.</p> <p style="text-align: right; font-size: small;">008_051514</p>

	 <b>DANGER</b>
	<p>Improper installation, adjustment, alteration, service, or maintenance can cause property damage, injury, or death. Any alterations to this equipment will void the warranty and may cause a dangerous condition. NEVER make alterations to this equipment. Read the Installation, Operating, and Maintenance Instructions thoroughly before installing, servicing, or operating this equipment.</p> <p style="text-align: right; font-size: small;">014_051514</p>



	 <b>WARNING</b>
	<p>To avoid burns, DO NOT touch heated surfaces.</p> <p>DO NOT place or leave objects in contact with heated surfaces.</p> <p style="text-align: right; font-size: small;">009_092414</p>



	 <b>WARNING</b>
	<p>ALWAYS wear safety glasses when servicing this equipment.</p> <p style="text-align: right; font-size: small;">010_010914</p>

	 <b>WARNING</b>
	<p>No user serviceable parts inside. Refer servicing to qualified service personnel.</p> <p style="text-align: right; font-size: small;">011_051514</p>

	 <b>WARNING</b>
	<p>Read and understand operator's manual and all other safety instructions before using this equipment. To order copies of the operator's manual go to <a href="http://gmpopcorn.com">gmpopcorn.com</a> or write to Gold Medal Products Co., 10700 Medallion Drive, Cincinnati, OH 45241 USA 1-(800)-543-0862</p> <p style="text-align: right; font-size: small;">022_060215</p>

## SAFETY PRECAUTIONS (CONTINUED)

	 <b>WARNING</b>
	<p>DO NOT allow direct contact of this equipment by the public when used in food service locations. Only personnel trained and experienced in the equipment operation may operate this equipment. Carefully read all instructions before operation.</p> <p>012_010914</p>

	 <b>WARNING</b>
	<p>This machine is NOT to be operated by minors.</p> <p>007_010914</p>

**Note:** Improvements are always being made to Gold Medal's equipment. This information may not be the latest available for your purposes. It is critical that you call Gold Medal's Technical Service Department at 1-800-543-0862 for any questions about your machine operations, replacement parts, or any service questions. (Gold Medal Products Co. does not assume any liability for injury due to careless handling and/or reckless operation of this equipment.)

# INSTALLATION

## CHECKING SHIPMENT

Your new Bag-In-A-Box Enclosed Butter Dispenser is ready for installation in your counter. Remove the machine from the corrugated carton. Check thoroughly for any damage, which may have occurred in transit. Damage claims should be filed immediately with the transportation company.

## ELECTRICAL REQUIREMENTS

Model No. 2396AC, 2396ACR – 120 Volts, 2.5 Amps, 300 Watts, 60 Hz

Model No. 2396ADC, 2396ADCR – 120 Volts, 2.9 Amps, 348 Watts, 60 Hz

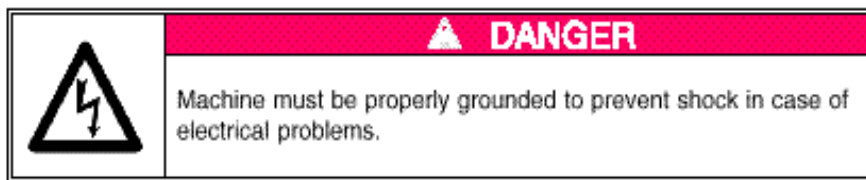

## INSTALLATION INSTRUCTIONS

1. The bottom portion of the enclosed butter dispenser rolls to an area under the counter where the pedestal is to be mounted. Access will be required to the front of this area allowing sufficient clearance to clean and maintain the pump and add or remove boxes of topping.
2. The countertop will require preparation by drilling the mounting holes and by cutting the rectangular holes for the power cable, the tube, the drip pan and remote switch. If your counter is thicker than the provided mounting studs attached to the pedestal, then counter bore the underside of the counter top to allow for the wing nuts.
3. Set the pedestal onto the counter top and secure it in place with the wing nuts.
4. Attach the heated-line tubing from the base to the aluminum tube on the pedestal with the hose clamp provided.
5. Plug the six-prong power cable from the pedestal into the side of the control box on top of the rack assembly.
6. Plug the power cord from the rack assembly into a proper outlet.
7. If this is a dual pedestal unit, turn the power on and test the connections. Press the dispense button and check to see that the correct pump is running to feed product to that pedestal. If not, turn the power off and simply switch the six-prong plugs to the opposite receptacle.
8. Load two boxes of pre-heated topping into the rack. Gold Medal's Backroom Warmer, Item #2262, may be purchased for pre-heating the topping. Remove the cardboard cutout on the box to expose the quick-disconnect fitting.
9. Attach the quick-disconnect fittings on the end of the tubing, to the fittings on the box of topping. The end fitting should attach to the upper box and the middle fitting should attach to the lower box.
10. The unit is now ready for use.

## OPERATING INSTRUCTIONS

1. Turn the master power switch, located on the front of the control box, to the **PUMP & HEAT** position. This will start the heater/blower that will maintain cabinet temperature, activate the foil heater in the pedestal, and provide power for the pump.
2. Pressing and holding either of the red buttons located on the pedestal will dispense topping. If this is the first time the unit has been used, it may take a minute to completely fill the tube and dispense topping.
3. Turn the master power switch, located on the front of the control box, to the **HEAT ONLY** position. This will start the heater/blower that will maintain cabinet temperature and activate the foil heater in the pedestal only. The pump is de-activated.

## CLEANING INSTRUCTIONS

### SANITIZING INSTRUCTIONS

Your Model 2396AC and 2396ADC is all stainless steel construction. The exterior surfaces can be cleaned by wiping oil spills with a dry towel, then wiping with another towel moistened with mild soap and warm water.

#### Sanitizing the internal parts; tubing, pump, etc.

1. Disengage the bag connector from the bag of oil and place in a pail of hot water and mild soap. Approximately 1 gallon.
2. Push the dispense button to flush the system of oil. Make sure you have a container under the discharge tube. Discard the oil.
3. Put the intake line in the hot water and pump it through the lines by holding the dispense button until the pail is empty.
4. Fill the pail with a sanitizing solution. Gold Medal offers a product for this purpose, Chlor-Tech, part number 1109. Put the bag connector in the pail of sanitizer. Pump it through the lines by holding the dispense button until the pail is empty. It is not necessary to flush the sanitizer before the next step, but you may flush with water if desired.
5. Before the next use, install the connector to a bag of oil and pump oil until oil is dispensed through the discharge tube.



### Schedule for Cleaning



The recommended sanitizing schedule is every night.



#### **IMPORTANT:**



This product is not intended for use with volatile food products, i.e. real butter.

# MAINTENANCE INSTRUCTIONS

	 <b>DANGER</b>
	<p>Machine must be properly grounded to prevent electrical shock to personnel. Failure to do so could result in serious injury, or death.</p> <p>DO NOT immerse any part of this equipment in water.</p> <p>DO NOT use excessive water when cleaning.</p> <p>Keep cord and plug off the ground and away from moisture.</p> <p>Always unplug the equipment before cleaning or servicing.</p> <p>Make sure all machine switches are in the OFF position before plugging the equipment into the receptacle.</p> <p style="text-align: right;">008_051514</p>

	 <b>DANGER</b>
	<p>Improper installation, adjustment, alteration, service, or maintenance can cause property damage, injury, or death. Any alterations to this equipment will void the warranty and may cause a dangerous condition. NEVER make alterations to this equipment. Read the Installation, Operating, and Maintenance Instructions thoroughly before installing, servicing, or operating this equipment.</p> <p style="text-align: right;">014_051514</p>

	 <b>WARNING</b>
	<p>No user serviceable parts inside. Refer servicing to qualified service personnel.</p> <p style="text-align: right;">011_051514</p>

	 <b>CAUTION</b>
	<p>THE FOLLOWING SECTIONS OF THIS MANUAL ARE INTENDED ONLY FOR QUALIFIED SERVICE PERSONNEL WHO ARE FAMILIAR WITH ELECTRICAL EQUIPMENT. THESE ARE NOT INTENDED FOR THE OPERATOR.</p> <p style="text-align: right;">027_010914</p>

## ORDERING SPARE PARTS

1. Identify the desired part by checking it against the photos, illustrations, and/or the parts list.
2. When ordering, please include part number, part name, and quantity desired.
3. Please include your model name and machine serial number (located on the machine nameplate) with your order.
4. Address all parts orders to:

Parts Department  
Gold Medal Products Co.  
10700 Medallion Drive  
Cincinnati, Ohio 45241-4807

or, place orders at:

(513) 769-7676  
(800) 543-0862  
Fax: (513) 769-8500  
E-mail: [info@gmpopcorn.com](mailto:info@gmpopcorn.com)

**PARTS LIST - DISPENSER ASSEMBLY**

Item No	Part No.	Description	2396ADC	2396AC
			Qty	Qty
1	12045	Catch Door	1	1
2	22038	Lead-in Cord 15 Amp plug	1	1
3	37513	Swivel Caster	4	4
4	38566	Butter Pump No Drip Spout	2	1
5	38796	Socket Cover	2	1
6	38773	Socket, Double Tube	2	1
7	38824	Modular Heat Element	1	1
8	38872	Pedestal Back Plate	2	1
9	38874	Pedestal Weld Assembly	2	1
10	38877	Top Pedestal Plate	2	1
11	38936	Drip Pan	2	1
12	38938	Pan Insert Weldment	2	1
13	38969	Spout	2	1
14	38970	Foil Heat Element, 8W 120V	2	1
15	38971	Momentary Switch	4	2
16	38990	Thermostat 135F	1	1
17	38995	Heater Deflector	1	1
18	38998	Retaining Strap	2	1
19	39012	8-32 x 2 PH PAN M/S 18-8	4	4
20	39142	Dispenser Label	4	2
21	103160	Light Cover Assembly	1	1
	103159	Light Cover	1	1
	103158	Butter Bracket	1	1
	47771	Head Tapping Screw	4	4
22	39150	Transformer Assy	1	1
23	39410	3 Position Rocker Switch	1	1
24	39413	Switch Label	1	1
25	39451	Top Cover	1	1
26	39452	Door	1	1
27	39453	Rack Weld Assy	1	1
28	39456	Divider Plate	1	1
29	39470	Panel Mount Wire Assy	2	2
30	39474	Tubing	2	1
31	39475	Tubing	1	0
32	39476	Tubing	2	2
33	39477	Tubing Tee	1	0
34	39480	Tubing Assy	2	1
35	39481	Manual	1	1
36	40721	Axial Fan	1	1
37	41033	Pilot Light - 125V Red	2	1
38	41163	Hose Clamp	14	8
39	41499	Wire Harness, Oil Pump	2	1
40	45396	Bushing Snap	1	1
41	47199	Blower plug and cord	1	1



## PARTS LIST - DISPENSER ASSEMBLY

Item No	Part No.	Description	2396ADC	2396AC
			Qty	Qty
42	49138	Hinge Left Hand Female	1	1
43	49139	Hinge Right Hand Female	1	1
44	49140	Hinge Right Hand Male	1	1
45	49141	Hinge Left Hand Male	1	1
46	55002	Resistor 150 Ohm 6.5 W	2	1
47	74636	Fuse Holder, Mighty Mite	2	1
48	74725	Ballast - 120V	2	1
49	74727	Lamp, Double Tube, 120V	2	1
50	76026	Strain Relief #SR-6P3-4	1	1
51	79100	Bag Connector, Dead Leg	1	1
52	79128	Bag Connector, Twin Outlet	1	0
53	79129	Cinch Jones Plug	2	1
54	79269	In Line Strainer	2	1
55	79341	1 AMP Fuse	2	1
56	79888	BIB Butter Pump	2	1
57	82221	Heyco Bushing	2	1
58	82698	Flush Mount Handle	1	1
59	89045	Strain Relief T&B #3302	4	2
60	39154	Remote Switch Assembly	2	1

# ELECTRICAL SCHEMATIC

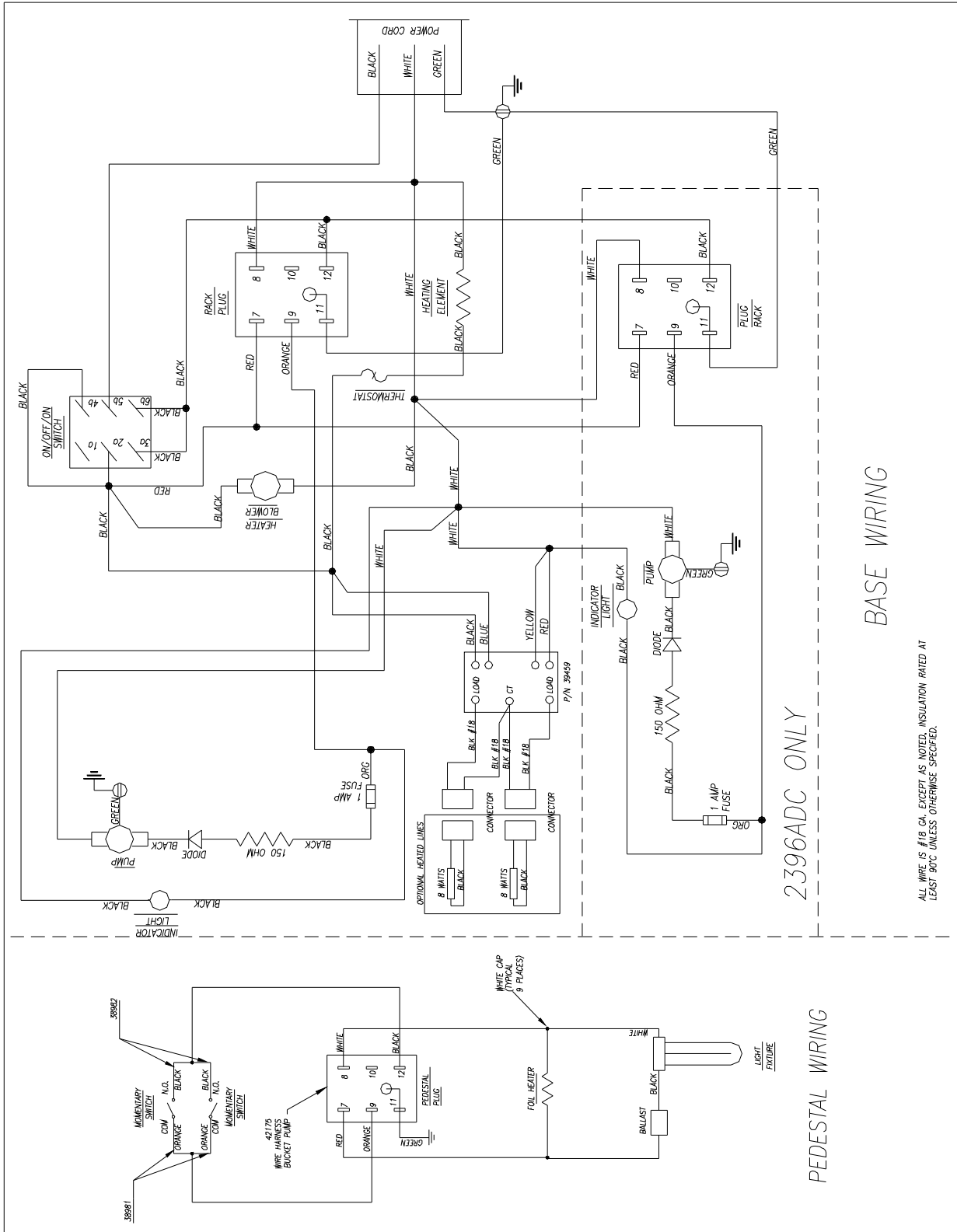

# ELECTRICAL SCHEMATIC

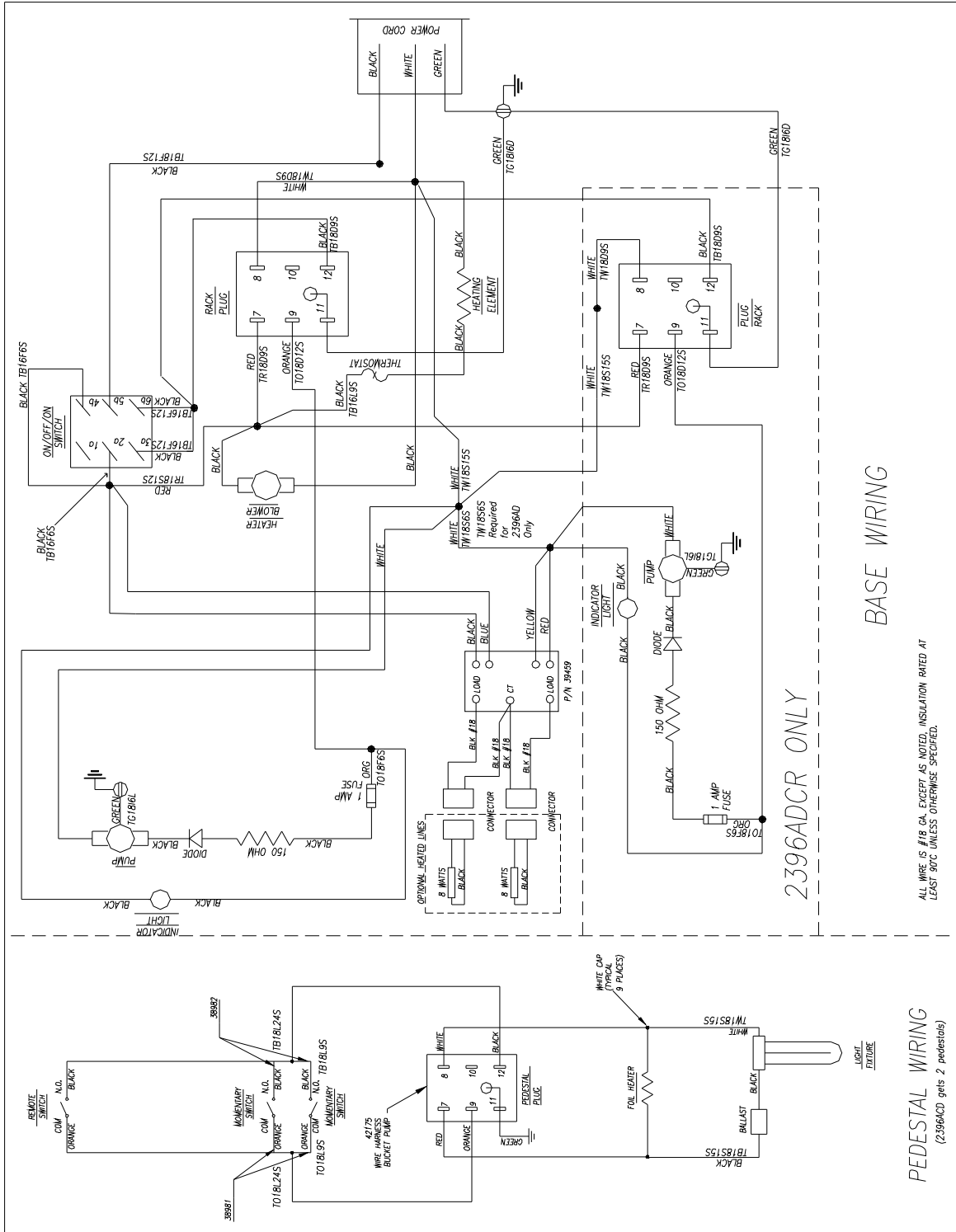

# COUNTER TOP CUTOUTS

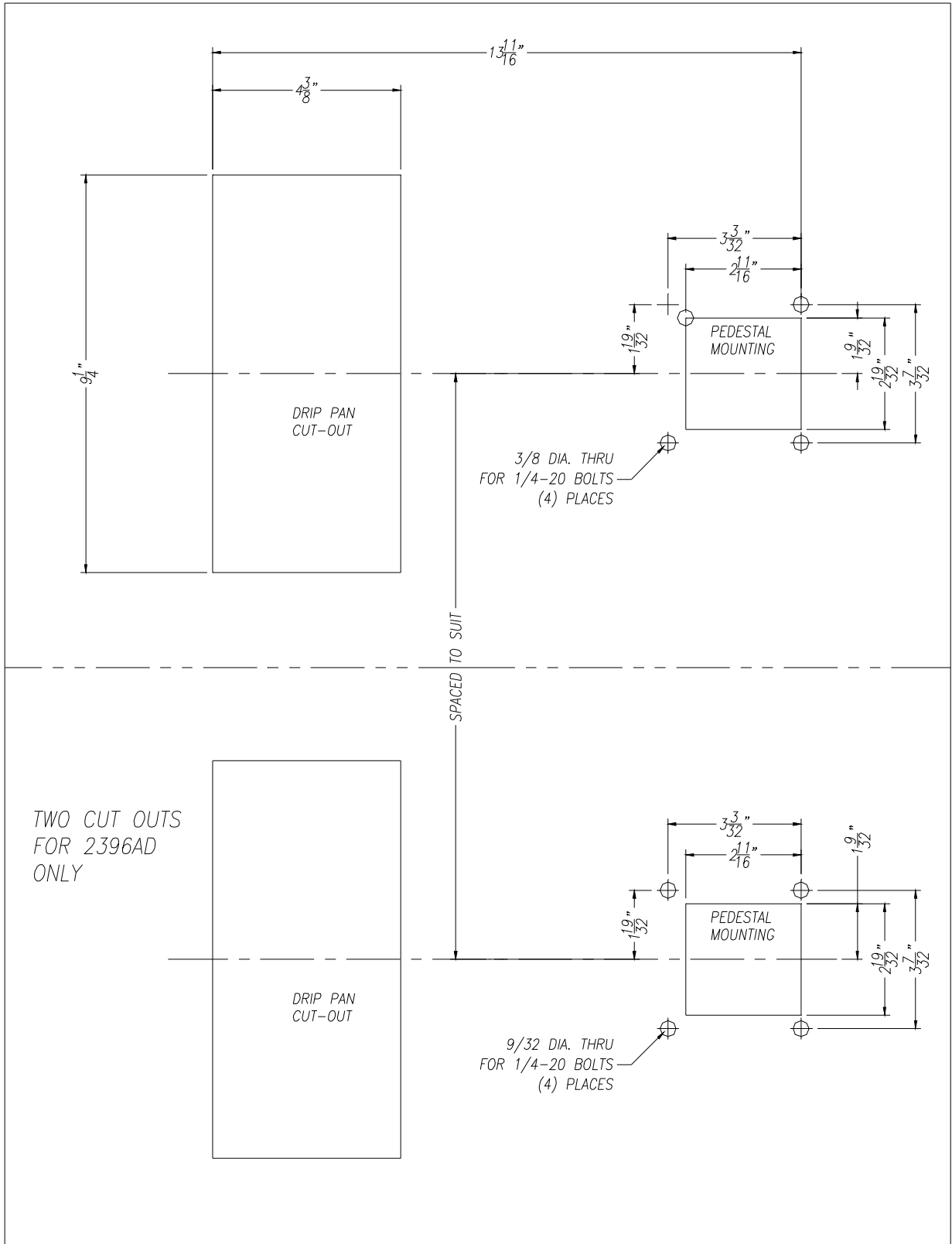

# COUNTER TOP CUTOUTS

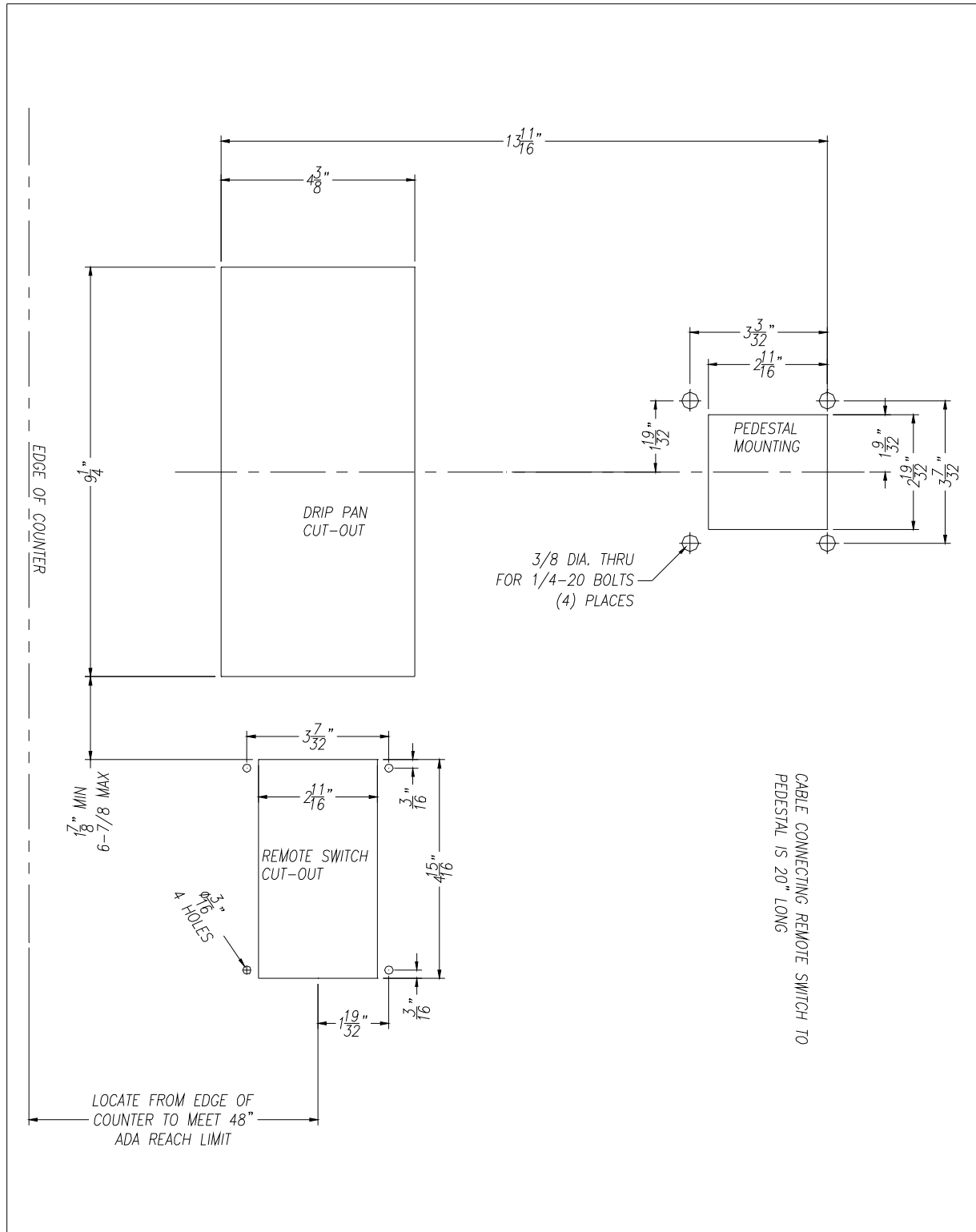

## WARRANTY

Gold Medal Products Co. warrants to the original purchaser each item of its manufacture to be free of defects in workmanship and material under normal use and service. Gold Medal Products Co.'s obligation under this warranty is limited solely to repairing or replacing parts, f.o.b. Cincinnati, Ohio, which in its judgment are defective in workmanship or material and which are returned, freight prepaid, to its Cincinnati, Ohio factory or other designated point. Except for "Perishable Parts" on specific machines, the above warranty applies for a period of two (2) years from the date of original sale to the original purchaser of equipment when recommended operating instructions and maintenance procedures have been followed. These are packed with the machine. Parts warranty is two (2) years, labor is six (6) months.

THIS WARRANTY IS IN LIEU OF ALL OTHER WARRANTIES EXPRESSED OR IMPLIED, AND OF ALL OTHER OBLIGATIONS OR LIABILITIES ON OUR PART, INCLUDING THE IMPLIED WARRANTY OF MERCHANTABILITY. THERE ARE NO WARRANTIES WHICH EXTEND BEYOND THE DESCRIPTION ON THE FACE HEREOF. In no event shall Gold Medal Products Co. be liable for special, incidental or consequential damages. No claim under this warranty will be honored if the equipment covered has been misused, neglected, damaged in transit, or has been tampered with or changed in any way. No claim under this warranty shall be honored in the event that components in the unit at the time of the claim were not supplied or approved by Gold Medal Products Co. This warranty is effective only when electrical items have been properly attached to city utility lines only at proper voltages. This warranty is not transferable without the written consent of Gold Medal Products Co.

The term "Original Purchaser" as used in this warranty shall be deemed to mean that person, firm, association, or corporation who was billed by the GOLD MEDAL PRODUCTS CO., or their authorized distributor for the equipment.

THIS WARRANTY HAS NO EFFECT AND IS VOID UNLESS THE ORIGINAL PURCHASER FIRST CALLS GOLD MEDAL PRODUCTS CO. AT 1-800-543-0862 TO DISCUSS WITH OUR SERVICE REPRESENTATIVE THE EQUIPMENT PROBLEM, AND, IF NECESSARY, FOR INSTRUCTIONS CONCERNING THE REPAIR OR REPLACEMENT OF PARTS.

*NOTE: This equipment is manufactured and sold for commercial use only.*



**GOLD MEDAL<sup>®</sup> PRODUCTS CO.**

10700 Medallion Drive, Cincinnati, Ohio 45241-4807 USA

[gmpopcorn.com](http://gmpopcorn.com)

Phone: (800) 543-0862      Fax: (800) 542-1496  
(513) 769-7676              (513) 769-8500

© 2016 – The text, descriptions, graphics, layout, and other material in this publication are the exclusive property of Gold Medal Products Co. and shall not be used, copied, reproduced, or published in any fashion, including website display, without its express written consent.