



Model No. 10x11 TS E
Counter Model
Instant Recovery® Fryer

PROJECT _____

QUANTITY _____

ITEM NO. _____

Standard Features:

- ▶ 13.6 kW input for cooking up to 40 lbs. of frozen french fries per hour
- ▶ Instant Recovery® for high production
- ▶ Stainless Steel cabinet
- ▶ Polished Stainless Steel fryer vessel
- ▶ Extra large Cold Zone
- ▶ Saves valuable space without sacrificing production
- ▶ Saves on oil costs/cooks at lower temperatures
- ▶ Indicating lights and timers
- ▶ Melt cycle

Options:

- Instant-On™
- Computer
- Thermostat Seal
- Portable Filter
- Security Package
- Cover



One pair 4 mesh baskets included

The 10x11 BB Electric Counter Model Fryer is ideal for multi-product use.

The 10x11 BB allows you to cook up to 40 lbs. of frozen french fries per hour with an input of 13.6 kW rated at 240 volts.

Keating saves oil costs in three ways:

- BETTER FRY POT DESIGN
- LARGER COLD ZONE
- INSTANT RECOVERY®

1. You shouldn't have to wait on the fryer. A properly designed fry pot ensures that the fryer has recovered its temperature before the end of the cooking cycle. Keating "INSTANT RECOVERY"® means continuous performance.
2. The Keating frying vessel is 27% Cold Zone, the food particles collected in the cold zone are unheated and therefore do not carbonize and contribute to premature shortening breakdown.
3. Keating's "INSTANT RECOVERY"® feature means frying at lower temperatures (325° – 335°F) extending oil life while enhancing product quality.

• **Oil Capacity - 30 lbs.**

Easy to clean

Keating uses only 304 stainless steel in its frying vessel design and polishes each vessel. The smoother the surface, the less carbon build-up occurs, making cleaning easier. A full one inch front drain allows easy draining of oil.

Safety controls ensure safe and accurate cooking. The patented and precise thermostat controls cooking temperatures to ± 3°F.

Hi-Limit control protects against the oil and fryer overheating.

Each fryer goes through a rigorous 100% test before shipping with every component carefully checked. The actual temperature test chart is included with each fryer.

Special Order Options

Keating gives you the widest range of options to ensure your fryer is exactly suited to your needs.



Intertek
9902091



Intertek
9902091



As continuous product improvement occurs, specifications may be changed without notice.

DATE _____

APPROVAL _____

SIGNATURE _____

www.keatingofchicago.com

10x11 TS Electric Counter Model Instant Recovery® Fryer

"Serving Those Who Serve The Very Best"®

KEATING
OF CHICAGO, INC.

Model No. 10x11 TS E Counter Model
Instant Recovery® Fryer

A minimum of 24" at the front of the unit should be allowed for servicing and operation; a minimum of 6" on each side and at the rear of each unit for combustible materials.

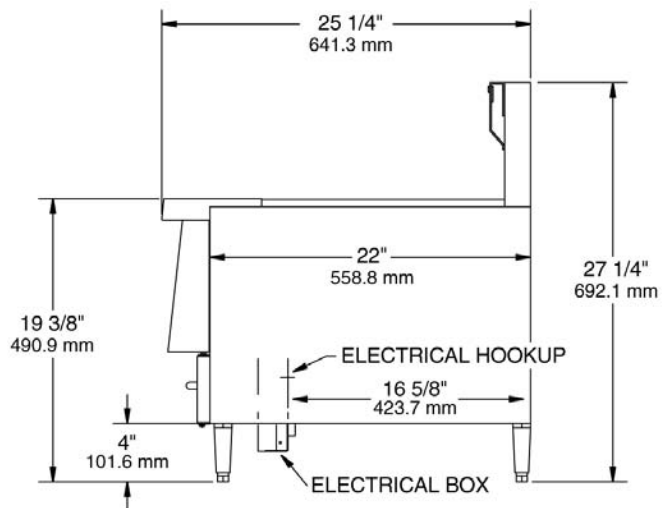
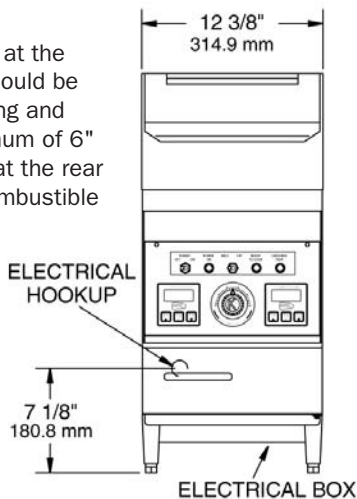

SPECIFICATIONS

Fryer Vessel - 18 gauge stainless steel, with a shortening capacity of 30 pounds. Equipped with three stainless steel electric elements, spaced above the bottom of the vessel so that the bottom is unheated and the food particles collecting in the bottom zone are unheated and therefore do not carbonize. The vessel is polished to inhibit carbon buildup and facilitate easy clean-up. The bottom of the vessel slopes toward the front, and is equipped with a 1" Teflon core 1/4 turn drain valve, so the shortening can be drained into a receiving vessel placed in front of the fryer.

Splashdeck - 16 gauge, 304 stainless steel. It slopes toward the shortening containing vessel.

Splashback - 18 gauge, 304 stainless steel. It completely covers the side of the flue.

Cabinet - 18 gauge stainless steel. Rigid in construction, with four 4" adjustable legs. The cabinet door is made of 22 gauge 304 stainless steel. The door covers the front of the cabinet from the bottom of the fryer to the fryer panel, and the full width of the cabinet. Above the panel is a canopy. No additional space is required for the door to open a full 90 degrees.

Electric Elements - Three electric elements, made of polished stainless steel.

Thermostat - Close range, hydraulic type, is accurate to ±3°F from 300° to 350°F with stainless steel bulb. Application of this thermostat is patented by Keating.

Hi-Limit Control - Manually resettable type with stainless steel bulb.

Melt Cycle - Standard on "TS" fryers, allowing the safe melting of solid shortening. Fryer is to be left in the Melt Cycle mode until oil completely covers elements.

Indicating Lights & Switches - Power on switch, melt idle fry switch, ready to cook light, over max temp light.

Standard Accessories - Includes two timers (programmable for three products each), one pair 4 mesh baskets, grid screen over elements, drain clean out rod, 1" x 11-1/2" drain extension and sample of Keating Klenzer.

Electric Specifications - 3-wire terminal block, with ground provided for field wiring. (See local codes for supply line requirements.)

Special Order Options may include cover, thermostat seal, portable filter, Instant-On™, computer, and security package.

ELECTRICAL REQUIREMENTS

MODEL	208V		220V		240V		380V**		480V**	
	KW	Amps	KW	Amps	KW	Amps	KW	Amps	KW	Amps
10x11 TS E CM 208-240/1	10.2	49	11.4	52	13.6	57	11.4	30	13.6	28
10x11 TS E CM 208-240/3	10.2	28-28-28	11.4	30-30-30	13.6	33-33-33	11.4	17-17-17	13.6	16-16-16

* Denotes height from top of counter to top of fryer deck.

** 380V or 480V are special order items.

DIMENSIONS

Working Height*	Overall Height	Depth	Width	Weight
19 3/8"	27 1/4"	25 1/4"	12 3/8"	120 lbs.

As continuous product improvement occurs, specifications may be changed without notice.

www.keatingofchicago.com

10x11 TS Electric Counter Model Instant Recovery® Fryer