

Snapshot

The **FXAF-12B** is a single-housing water treatment system with a drop-in 4.5" x 20" high-capacity, dual-density sediment cartridge that takes out dirt, rust and other particulates down to 5 microns. The system can be used as a point-of-use sediment reduction filter; or it can be applied prior to a primary filtration system to provide additional prefiltration to protect against premature plugging due to excessive dirt and sediment levels found in some water supplies. System includes a pressure gauge, inlet ball valve and mounting bracket.

System Benefits

- Gradient-density sediment filtration protects against dirt, rust and other debris down to 0.5 microns.
- Protects down-line filtration systems against premature plugging, reducing filter change frequency and associated cost.
- Sturdy mounting bracket and full-flow inlet shut-off valve simplify installation.
- Built-in pressure gauge allows visual monitoring of when filters need to be changed.
- Inlet shut-off and depressurization valves make filter replacement quick and simple.
- Minimizes waste by only replacing drop-in cartridge and reusing filter sump.

ITEM #: _____ QTY: _____
JOB NAME/NUMBER _____



Application

ALL EQUIPMENT APPLICATIONS - *When excessive sediment is a problem.*

EXISTING FILTRATION SYSTEMS - *Provides added prefiltration to extend filter life.*

Installation Tips

- Feed-water connection to system should be COLD only.
- Do not exceed system specifications for temperature and pressure.
- Allow 3" clearance below system for filter housing removal and cartridge replacement.
- Detailed installation, operation & maintenance manual included with each system.
- No activation procedure or flushing required for system to perform as specified.

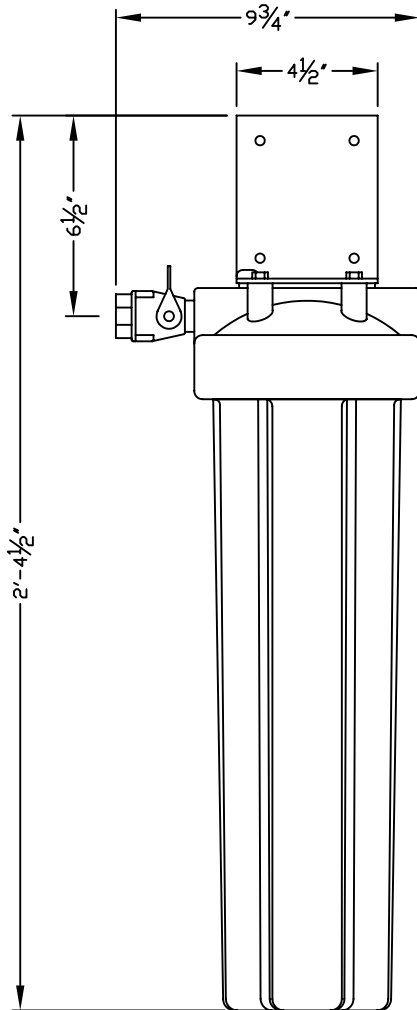

► Specifications

System	
Dimensions Height x Width X Depth, inches	24-1/2" x 9-3/4" x 5-1/8"
Connection - Inlet & Outlet	3/4" NPT female
Operating Pressure Range	10-125 psi (0.7 -8.6 bar)
Inlet Water Temperature Range	35 - 100°F (2 - 38°C)
Shipping Weight	18 lbs.
Performance	
Chlorine, Taste and Odor Reduction Capacity	N/A
Service Flow Rate	8.0 gpm (30.3 lpm)
Sediment Reduction	5 micron (nominal)
Scale & Corrosion Inhibitor	N/A

Optional Flush Valve Kit - Part #: 160-52914

► Replacement Cartridge(s)

Model	Part Number	Qty
S5-20B	252-10410	1

It is recommended that filters be changed every six months, when capacity is reached or when effluent pressure or flow becomes inadequate.

This product is for commercial use only and must be installed and maintained according to manufacturer's guidelines.

Do not use on water that is microbiologically unsafe or of unknown quality without adequate disinfection before or after the system.

► Warranty

Systems have a 3-year warranty against defects in material and workmanship. For complete warranty information, contact OptiPure customer service.

Dealer/Distributor Info:

OptiPure, a division of AQUION
2605 Technology Dr., Bldg 300 Plano, TX 75074
p: 972.881.9797; f: 972.422.6262
e: info@optipure.net www.optipurewater.com