

Snapshot

The **FXWS-12B** is a single-housing water treatment system with a drop-in 4.5" x 20" high-capacity ion-exchange (softening) cartridge that removes calcium and magnesium hardness minerals from water. The system also takes out dirt and sediment down to 10 microns. The system can be used as a point-of-use softening filter, or it can be applied to a specific point-of-use down-line in combination with a primary system.

System Benefits

- Takes out hardness minerals that form damaging scale (lime-scale).
- Reduces maintenance frequency and cost, and extends equipment life.
- Reduces dirt, rust and other debris as small as 10 microns.
- Sturdy, powder-coated mounting bracket and full-flow inlet shut-off valve simplify installation.
- Built-in pressure gauge allows visual monitoring of when filters need to be changed.
- Inlet shut-off and depressurization valves make filter replacement quick and simple.
- Minimizes waste by only replacing drop-in cartridge and reusing filter sump.

ITEM #: _____ QTY: _____

JOB NAME/NUMBER _____



Application

ESPRESSO - traditional, semi-auto and super-automatic machines.

TEA BREWERS

Installation Tips

- Feed-water connection to system should be COLD only.
- Do not exceed system specifications for temperature and pressure.
- Allow 3" clearance below system for filter housing removal and cartridge replacement.
- Do not use for condenser water.
- Detailed installation, operation & maintenance manual included with each system.
- Flush the cartridge for two minutes prior to connecting equipment.

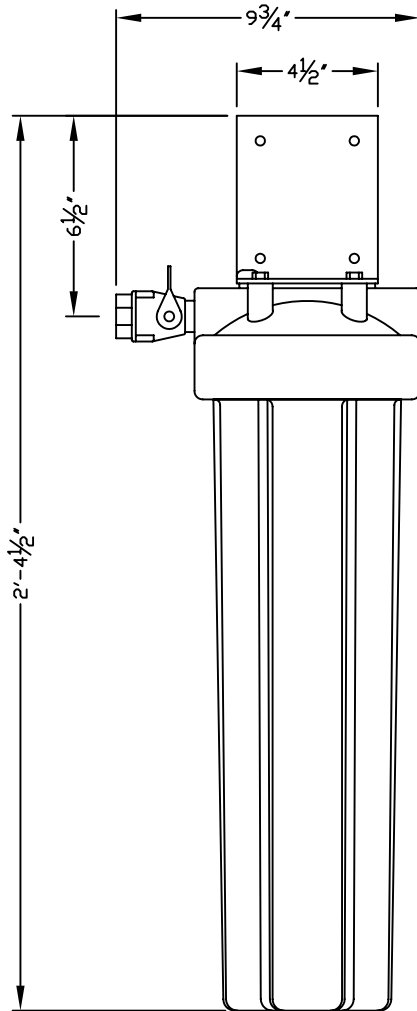

► Specifications

System	
Dimensions Height x Width x Depth, inches	28-1/2" x 9-3/4" x 8-1/2"
Connection - Inlet & Outlet	3/4" NPT female
Operating Pressure Range	10-125 psi (0.7 -8.6 bar)
Inlet Water Temperature Range	35 - 100°F (2 - 38°C)
Shipping Weight	22 lbs.
Performance	
Water Softening Capacity	5,200 grains
Service Flow Rate	2.0 gpm (7.6 lpm)
Sediment Reduction	10 micron (nominal)
Scale Prevention	Ion Exchange

Optional Flush Valve Kit - Part #: 160-52914

► Replacement Cartridge(s)

Model	Part Number	Qty
WS-20B	252-60040	1

It is recommended that filters be changed every six months, when capacity is reached or when effluent pressure or flow becomes inadequate.

This product is for commercial use only and must be installed and maintained according to manufacturer's guidelines.

Do not use on water that is microbiologically unsafe or of unknown quality without adequate disinfection before or after the system.

► Warranty

Systems have a 3-year warranty against defects in material and workmanship. For complete warranty information, contact OptiPure customer service.

Dealer/Distributor Info:

OptiPure, a division of AQUION
2605 Technology Dr., Bldg 300 Plano, TX 75074
p: 972.881.9797; f: 972.422.6262
e: info@optipure.net www.optipurewater.com