

# OptiPure<sup>®</sup>



OptiSoft  
OS-10, OS-13,  
OS-20 & OS-29  
Softeners

Installation, Operation  
& Maintenance Manual  
Rev. 1

**Manufactured By:**  
**OptiPure Div. of**  
**Procam Controls, Inc.**  
**2605 Technology Drive, Bldg. 300**  
**Plano, TX 75074**  
**P: 972.881.9797 F: 972.422.6262**

## Service Contact

For local maintenance and service information please contact your nearest Authorized Service Representative. Service inquiries may be directed to technical support at:

OptiPure div. of Procam Controls, Inc.  
2605 Technology Dr. Bldg. 300  
Plano, TX 75074 USA

Phone #: 972.881.9797  
Fax #: 972.422.6262

E-mail correspondence to:  
techsupport@optipure.net

## Safety Instructions

1. Please read and follow these instructions when connecting and using the system.
2. Plumbing and electrical connections should be performed by qualified persons in accordance with local codes.
3. Never use the system if the power cord or other parts of the system have been damaged. Do not allow anything to rest on the power cord, and keep the cord away from any place where people may trip over them.
4. Do not lay the softener on its side.
5. When disconnecting from the electric socket hold the plug, not the cord.
6. Unplug the softener prior to any service.
7. Use approved Air-Gaps when connecting to drain lines.
8. Do not exceed system pressure/temperature rating and use water hammer arrestors when water hammer is evident.
9. Use flexible hoses for connecting the softener

## Installation Requirements

This product must be installed and maintained in accordance with manufacturer's guidelines and local regulatory plumbing and electrical codes.

### Location

The system should be installed indoors, in the proximity (within 25 feet) of the equipment to be fed by the softener, and protected from the elements. Do not let the softener freeze or be exposed to rain, direct sunlight, or high ambient temperatures. Ensure the floor under the softener is clean and level.

### Feed water operating parameters

Minimum Temperature:	35° F (2° C)
Minimum Pressure:	20 psi (1.4 bar)
Maximum Temp/Pressure:	120° F (48° C) at 120 psi (8.3 bar)
	---OR---
	149° F (65° C) at 73 psi (5.0 bar)

### Feed water supply

An adequate flow and pressure of water to the unit is essential for successful operation. Provide a dedicated 3/4" water line (1/2" minimum) to the immediate location of the installation. Less than 2 feet from the rear side of where the softener is to be installed, install a water supply ball valve (user supplied, 3/4" recommended, 1/2" minimum). Come out of the water supply valve with a 3/4" male pipe thread fitting for connection to the 24" long flex hoses provided with the softener. Use the supplied metal flex hoses or other flexible hose for both inlet and outlet connections to the softener.

### Drain requirements

A drain near the floor level should be located within 5 feet of the location of the unit. Plastic pipe of either 1-1/4" or 1-1/2" is recommended for the drain connection. The drain connection should be accessible for system set-up and service. Drain must allow a minimum flow of 12 gallons per minute. Use the supplied air gap or other approved air gap that allows for two 1/2" drain connections. (Use two separate hoses for the two drains.) The supplied air gap fits either 1-1/4" or 1-1/2" plastic pipe.

### Electrical requirements

A power source (110V, 60Hz, 17 watt) should be located within 5 feet of the location of the unit.

Specifications

**Softener inlet/outlet connections**

The connectors on the softener unit are 3/4" male pipe thread. Two corrugated metal flex hoses, 24" long, with female 3/4" pipe thread ends, are supplied for connecting to 3/4" male fittings for the feed water and downstream plumbing. Use these or similar flex hoses for making connections to the softener rather than hard-plumbing to the softener with metal or plastic pipe. Each of the swivel connectors at the ends of the flex hose has a rubber seal to make a seal to the end of the pipe fitting to which it is connected. They require no thread tape and should only be tightened snugly, without over-tightening.

**Hardness blending capacity**

The softener is supplied with a blending valve to introduce some hardness from the feed water into the treated water outlet. The valve can be used to control how much hardness is in the treated water,

with a maximum of approximately 25-30% of the feed hardness.

**Model specifications**

Model	OS-10	OS-13	OS-20	OS-29
Size (resin capacity, cuft)	0.3	0.4	0.6	0.9
Nominal exchange capacity (kilograins)*	5.0	7.5	12.6	18.3
Salt usage per regen. (lb)	2.4	3.3	5.1	7.3
Recommended maximum flow (gpm)	4.0	5.3	7.9	11.4
Weight (lb)	34	44	58	79
Salt storage capacity (lb)	30	37	51	77

\*Softened water capacity (gallons) between resin regeneration cycles depends on feed water hardness.

Equipment Dimensions

**OS-10 Micro**

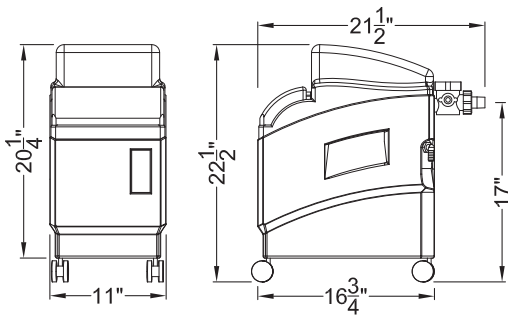

**OS-13 Mini**

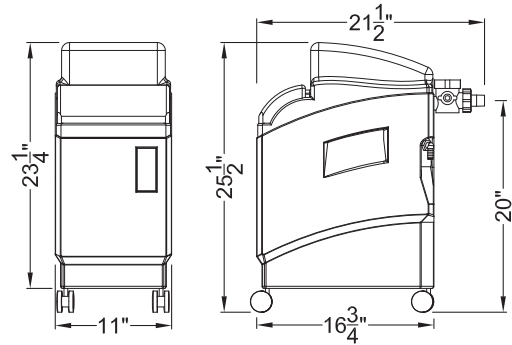

**OS-20 Midi**

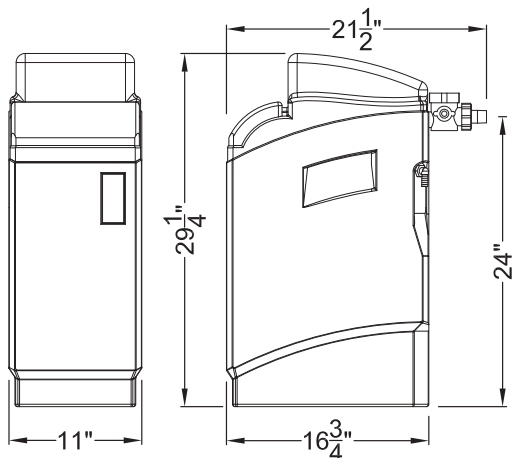

**OS-29 Maxi**

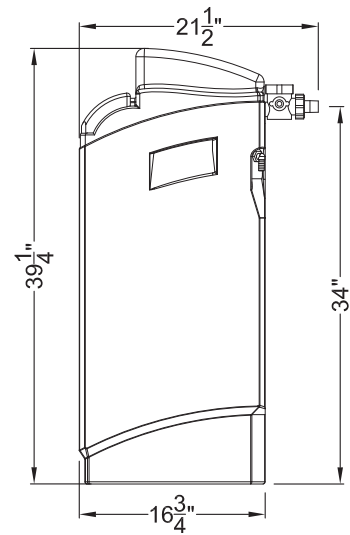

# Getting To Know Your System – Important Components

The OptiSoft softener works to condition water for use by downstream equipment, by removing minerals and exchanging them for sodium ions (from the salt in the brine tank). It automatically tracks the softening capacity remaining in the resin and performs a resin regeneration cycle as needed to replenish the resin's softening capacity. It incorporates a **Blending Valve** to enable blending some hardness back into the treated water (up to 25–30% of the feed hardness), to supply water to your equipment with the characteristics that you desire.

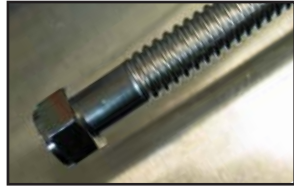

Flex hoses (2)



Pipe thread adapters (2) - fit onto bypass assy inlet/outlet

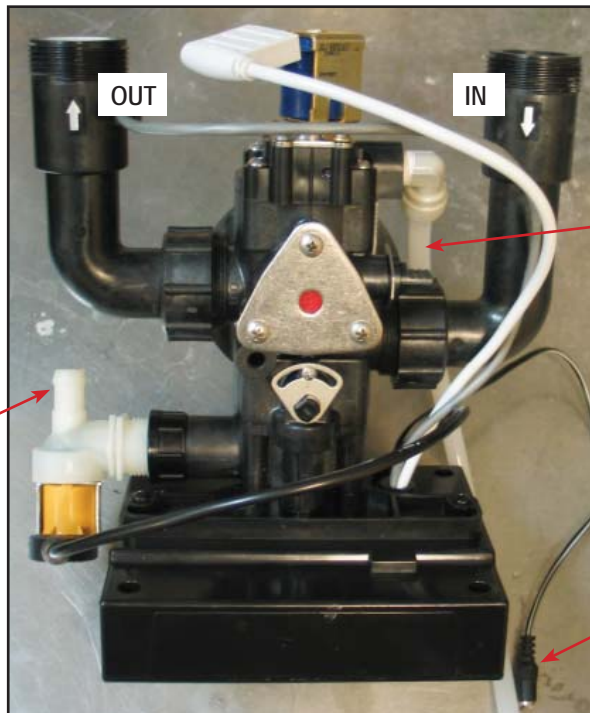
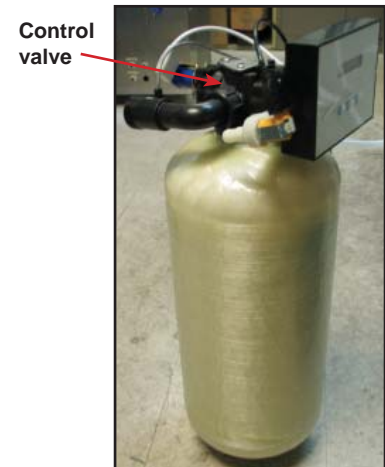
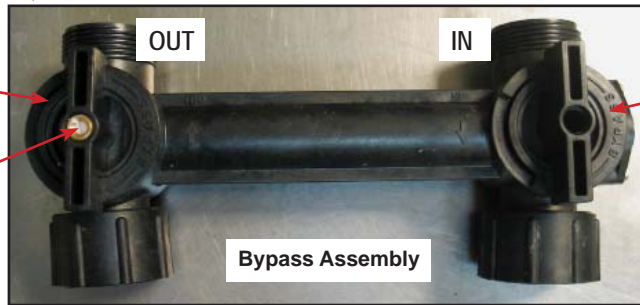

Control valve display



Buttons: Scroll Up Arrow Down Arrow



Power transformer



Drain air gap

## System Installation

1. Unpack the softener and inspect for damage. Locate the softener so as to allow full access to all sides of the tank. Remove the salt lid and main cover.
2. Lift up the mineral tank and remove bagged parts from inside the bottom of the brine tank.
 

**NOTE: Do not remove the protective filter bag from the bottom of the suction tube (photo B).**
3. **(OS-10 & OS-13 Only)** Place the softener on its side. Holding the metal reinforcement plate in

place on the bottom of the softener cabinet, screw and tighten the casters into the threads at the four corners, using the supplied washers. Place the two casters with brakes at the front (or wherever they will be most accessible). Place the cabinet in an upright position.

4. Identify the control valve drain hose connection, which is a white hose barb on the left side of the control valve, pointing toward the rear of the unit (see photo D). Using a piece of 1/2" reinforced hose long enough to reach from the softener to the drain, install a drain hose on the control valve drain hose barb. Secure it with a supplied plastic clamp, and tighten the clamp with pliers. Flow from this drain will be under pressure.



A. Softener with covers removed

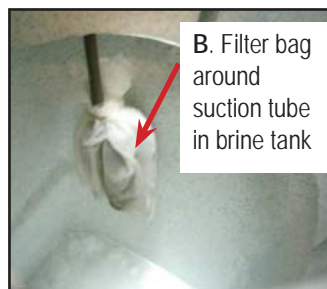

B. Filter bag around suction tube in brine tank



C. OS-10 with casters

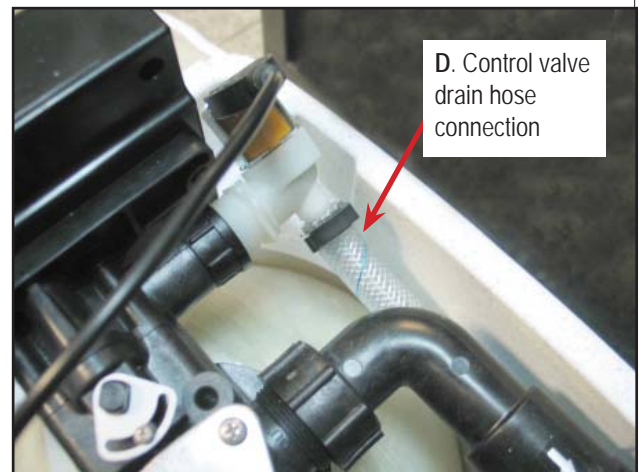

D. Control valve drain hose connection



E. Pipe thread adapter



F. Ensure gaskets are installed in both connections of bypass assy

5. Identify the pipe thread adapters (see photo E), and see the arrows which appear on the side of each one. (Ensure the gasket is in place inside the black plastic nut, on both adapters.) Install the one with the arrow pointing toward the black plastic end onto the **inlet** of the bypass assembly. Install the one with the arrow pointing toward the brass end onto the **outlet** of the bypass assembly.
6. Install the bypass assembly onto the inlet/outlet connections on the rear of the control valve, being sure to use the gaskets in the connectors. Hold the bypass assembly in place with inlet/outlet horizontal, and tighten the nuts firmly by hand (photos F, G).
7. Tighten all the connections (photo H) on the softener using slip-joint pliers, but do not overtighten the fittings. (Overtightening will cause leaking by distorting the seals or cracking the plastic.)
8. Using one of the supplied 24" long metal flex hoses, make the connection from the feed water supply valve to the inlet of the bypass assembly (photo H). Each of the connectors at the ends of the flex hose is 3/4" FPT, with a rubber seal in it to

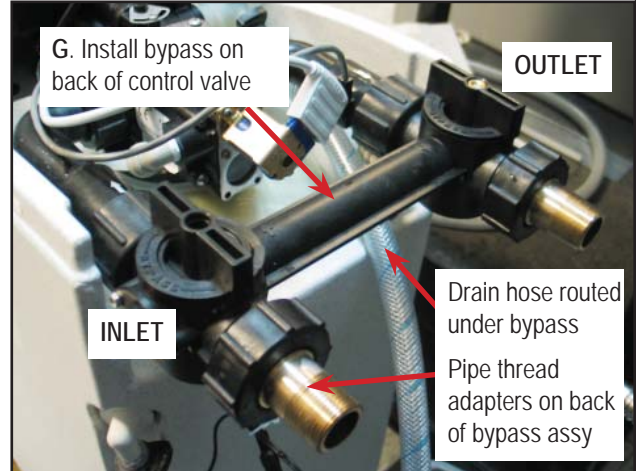

make a seal to the **end** of the 3/4" MPT fitting to which it is connected (photo I).

**The metal flex hose swivel connectors do not require thread tape, and they should not be tightened as tight as ordinary pipe fittings. Tighten the nuts snugly with a wrench; over-tightening will distort the rubber seals and cause leaking.**



I. Flex hose swivel connectors with rubber seals

Bend the flex hose as needed to make the connection so the fittings are not under stress.

**NOTE: Do not hard-plumb all the way to the softener using metal or plastic pipe.**

9. Attach the other 24" metal flex hose to the outlet of the bypass assembly and tighten the nut.

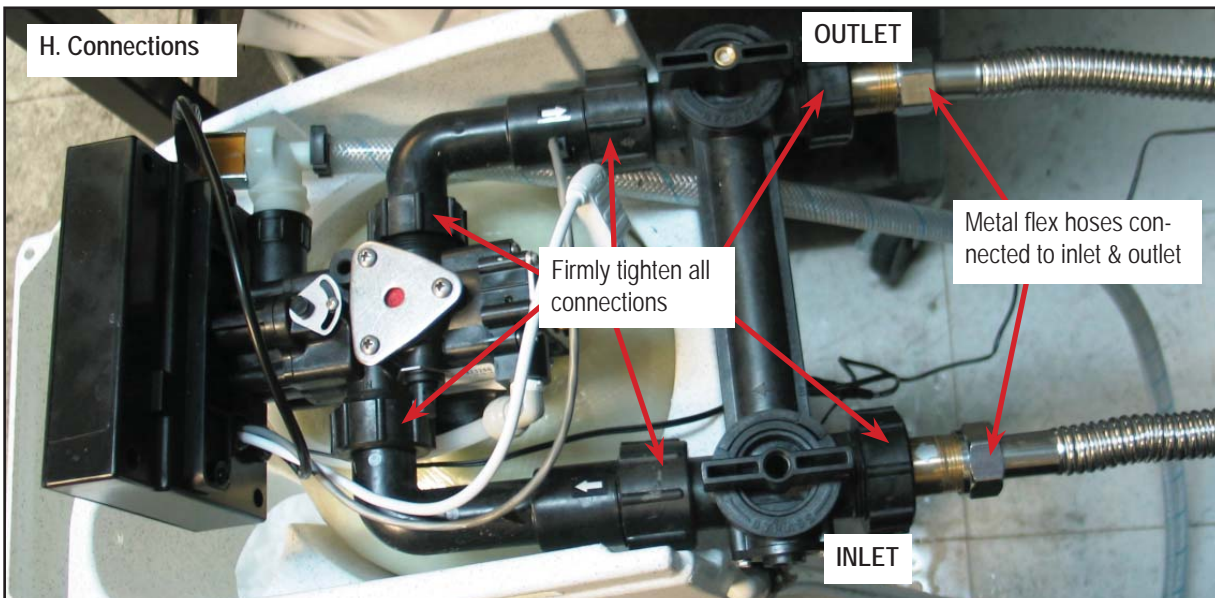



J. Hose barb adapter & 1/4" hose used to make temporary connection from softener outlet to drain.



K. Cabinet drain connection



L. Supplied air gap fits inside 1-1/2" plastic pipe



M. Twist clamp securing connected wires

10. For startup, a temporary connection must be made between this flex hose at the outlet, and the drain. Using a 1/4" hose barb x 3/4" MPT adapter, connect a piece of 1/4" hose to the metal flex hose and route it to the drain (photo J). Fasten it firmly at the drain so that it does not move under water pressure. (Water will spray as if from a nozzle, so ensure the flow is directed so as to be contained in the drain.)
11. Using a second piece of 1/2" hose long enough to reach from the softener to the drain, install a drain hose onto the cabinet overflow elbow on the rear of the softener cabinet (photo K), and secure it with a clamp.
12. Route the two 1/2" drain hoses to the drain. Do not attempt to use a single hose for both drains. Take care with the drain from the cabinet overflow to route it so the hose does not rise above the height of the overflow outlet on the cabinet, as this will prevent overflow from draining. The drain from the control valve will operate under pressure, so it does not need to be routed as carefully as the cabinet overflow hose.
13. At the drain, plan the drain connections, but **do not make permanent connections of the drain hoses or air gap at this time.**

The drain connections will later be made using the supplied air gap fitting or another approved air gap connection that allows for two 1/2" hose connections. **The supplied air gap fitting may be fitted (using PVC cement) over the outside of a 1-1/4" plastic pipe, or inside a 1-1/2" pipe (photo L). If the drain pipe is neither of these sizes, then accommodation will need to be made at this time in preparation for installation of an air gap. Ensure also that the drain is as close to the floor as possible, to ensure downhill flow from the softener cabinet overflow**

### hose connection to the drain.

14. Temporarily place the ends of the two 1/2" drain hoses into the drain.
15. Plug the power transformer output connector to the socket on the wire coming out the back of the control valve. Secure the wires together with the twist clamp (photo M) to prevent it from inadvertently coming unplugged.
16. Plug the transformer into the electrical outlet.

## Control Panel Setup

When making the following settings, note that if no buttons are pressed on the control panel for 5 minutes, the controller will automatically return to service mode and **no changes will be saved. The up or down arrow button *must* be pressed after stepping through all the settings for any setting changes to be saved.** (See step 6.)

1. Perform a test to determine the total hardness of your feed water, preferably in grains per gallon (written as "grains" or "gpg"). Note the units used by your testing method. (If you have the hardness expressed in "mg/L" or "ppm", you can divide this number by 17.2 to convert to grains.) **Record the results of this test.**  
  
Note: if you have additional Iron in your water, 1 ppm of Iron counts as 4 gpg of hardness. (e.g., if you have 10 grains of ordinary hardness + 2ppm of Iron, this counts as 10 + 2x4 = 18 grains)
2. To enter programming mode on the control panel, press the scroll button  and hold it until the display shows

Language: English

Press up or down arrow buttons to change the language.

3. Press and release the scroll button , and the display will show the time, similar to

Set time: 8:01AM

Press up or down arrow buttons to increment the time forward or backward to the current time.

4. Press and release the scroll button , and the display will show

HardUnit: Grns

Press up or down arrow buttons to change to the desired units for hardness (usually grains = gpg).

5. Press and release the scroll button , and the display will show

Set Hardn:10 gpg

Press up or down arrow buttons to set the hardness to that of your feed water (determined in step 1).

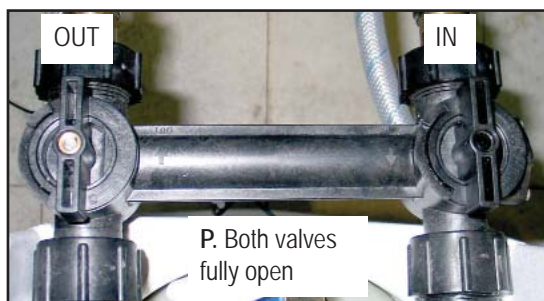
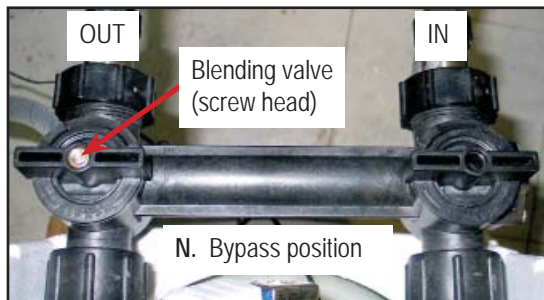

6. Press and release the scroll button , and the display will show

Exit

**IMPORTANT: Press either the up or down arrow button to save the settings you entered and exit programming mode.**

## Startup

1. Ensure both valves on the bypass assembly are in "bypass" position (photo N).
2. Use a flathead screwdriver to close the hardness blend adjustment valve (photo N) on the outlet of the bypass assembly, by turning it all the way clockwise.
3. Slowly open the valve at the water supply.
4. Allow water to run to drain briefly to flush the line.
5. On the softener bypass, open the outlet valve (photo O).
6. Slowly open the inlet valve (photo P). Water will fill the mineral tank, then begin to flow from the outlet.
7. Observe the water coming from the outlet (note any discoloration or air bubbles). Allow water to continue to flow to drain to flush the system.
8. Manually add tap water to the brine tank, to a height of 4" to 6" in the bottom.
9. Add salt to the brine tank (photo Q), until the cabinet is 1/3 to 2/3 full. Do not fill higher than 2/3.
10. Check the water coming from the outlet. Allow water to flow to drain until all air is purged and any bubbles and discoloration are flushed from the resin.



## Hardness Adjustment

If some hardness in the treated water is desired, use the blend adjustment valve, located on the outlet valve of the bypass assembly (photos R), to adjust the hardness to the desired setting. The blend valve will increase the hardness of the treated water by approximately 6% of the feed hardness, for each complete turn counter-clockwise, up to 4 turns. (Beyond 4 turns, only a slight additional hardness increase is likely.) The maximum hardness possible with blending is 25–30% of feed hardness, with the valve open to approximately 7 turns. Complete the following steps, recording the results of hardness tests (and corresponding blend valve settings) each time a test is performed:

1. If closed, open the water supply valve, in order to allow flow from the softener outlet to the drain.
2. With the blend valve still completely closed, collect a sample of the treated water coming from the softener outlet. Verify softening effectiveness by performing a hardness test on the treated water. (This is a blend setting of “0 turns”.)

**NOTE: If your desired hardness is less than 25% of the feed water hardness measured previously during “Control Panel Setup,” then follow the steps below to set the blend to achieve the desired hardness. Otherwise, open the blend valve all the way to achieve the maximum possible hardness, and skip to step #9 below.**

3. (See photo.) Using a felt tip pen, put a mark -

aligned with the screw slot - on the brass housing of the blend valve adjustment screw, at one end of the screw slot. This mark will be your reference point when counting turns of the adjustment screw. Also mark the end of the screw slot adjacent to the mark you placed on the housing.

4. Based on your desired treated water hardness, estimate the required blend setting, using the **feed hardness** measurement you determined previously during “Control Panel Setup”:

a. First, calculate the Hardness Increase Per Turn:

$$\text{Hardness Increase Per Turn} = 0.06 \times \text{Feed Hardness}$$

b. Then calculate the Estimated Blend Setting:

$$\text{Estimated Blend Setting} = \frac{\text{Desired Hardness}}{\text{Hardness Increase Per Turn}}$$

Round this number off to a single decimal place. This is the approximate number of turns counter-clockwise that the blend valve should be turned to achieve the desired hardness.

- Note that the highest available hardness is at a blend setting of approximately 4 turns. A higher hardness than this may not be possible with adjustment of the blend valve. However, to achieve the maximum possible hardness, open the blend valve all the way (approximately 7 turns).**

5. Using a flathead screwdriver, open the blend valve to the Estimated Blend Setting, carefully counting complete turns of the mark on the slot in the adjustment screw, plus any fraction of a turn after the decimal place.

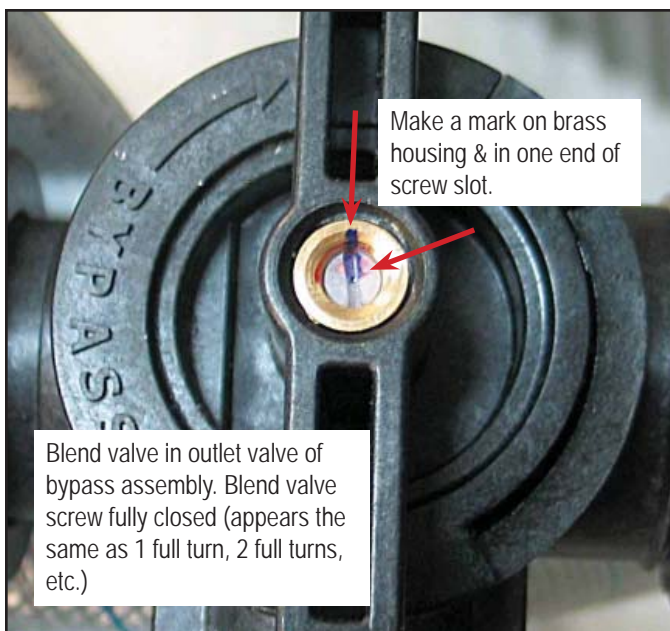

Photos R. Blend valve setting

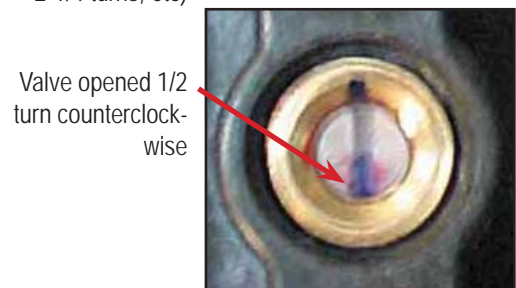
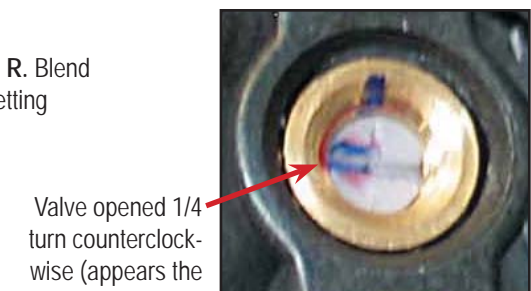

6. Perform a hardness test on a sample of the treated water coming from the softener.
7. If the measured hardness is less than the desired hardness, make small correcting adjustments by turning the screw counter-clockwise (noting the fractional amount of a turn), performing a hardness test after each adjustment, until the desired hardness is achieved. The final blend setting is equal to: Estimated Blend Setting + total sum of fractional turns made counter-clockwise to correct.
8. If the measured hardness is more than the desired hardness, make small correcting adjustments by turning the screw clockwise (carefully noting the fractional amount of a turn), performing a hardness test after each adjustment, until the desired hardness is achieved. The final blend setting is equal to: Estimated Blend Setting - total sum of fractional turns made clockwise to correct.
9. **Make a record of the final treated water hardness measurement and the final blend setting.** You may wish to place a piece of tape over the blend adjustment screw to avoid having the adjustment inadvertently changed.
10. Close the water supply valve.

## Completing the Installation

Once the blend valve has been set to the desired hardness, the installation can be completed and the unit placed in service.

Remove the temporary hose adapter and 1/4" hose from the softener outlet to the drain.

Install the air gap at the drain (photo S). Ensure the air gap is secured permanently in place. Connect each of the drain hoses to the air gap, securing each with a clamp.

Complete the connection of the 3/4" outlet flex hose to the plumbing feeding the downstream equipment. Open the water supply valve, and ensure both inlet and outlet valves of the bypass assembly are fully open. Check all fitting connections on the softener for any leaks. (Close the water supply valve if necessary to correct any leaks, then re-open valve.) Verify availability of treated water to the downstream equipment, and check for plumbing leaks downstream of the softener.



S. Drain hoses connected to air gap at drain pipe

## Bypassing the Softener

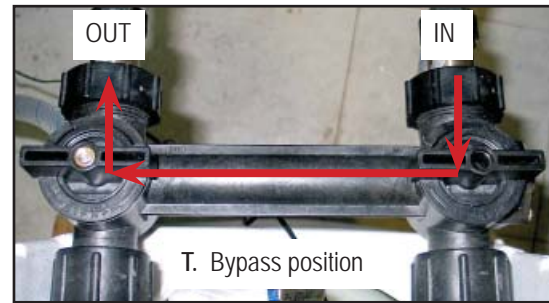

If it ever becomes necessary to bypass the softener for service while allowing feed water to flow to downstream equipment, the bypass assembly on the softener can be used. To simply place the softener in bypass mode, turn **both** valves on the bypass assembly on back of the softener to the bypass position (photo T).

**Note: The mineral tank of the softener will still contain pressurized water when the valves on the bypass assembly are closed. Perform the following steps to release pressure.**

If the softener is to be disconnected or opened up, then

1. Close the feed water supply valve and temporarily open a valve downstream of the softener to release the water pressure inside the softener.
2. Then turn the valves on the softener bypass to the bypass position to isolate the softener from feed pressure.
3. The water supply valve can then be re-opened if water is needed downstream.

## Understanding the Controller

The controller determines the softening capacity of the resin based on the feed water hardness which the user inputs into the controller (during “Control Panel Setup” above). As softened water is being used, the controller measures the water volume used and tracks when the softening capacity is consumed.

When the capacity has been used, the controller performs an automatic regeneration of the softener resin (by backwashing with the salt brine stored in the brine tank) to restore the resin to the original softening capacity. This depletes salt from the mineral tank. Salt must therefore be manually added to the mineral tank to supply brine for subsequent resin regeneration cycles.

**Buttons:** The control panel has three buttons for the user to do the controller setup and to initiate or stop a regeneration cycle. There is a “scroll” button  which is generally used for advancing the display to the next parameter. There are also buttons with an “Up” arrow and a “Down” arrow, generally used for increasing or decreasing the value of the parameter being set.

**Service Mode:** The normal operating mode of the control panel when the power transformer is plugged into an outlet is “service mode,” which is indicated on the panel by a display of the time of day and the remaining softening capacity, such as

8:01AM 1000GL-

**Startup or Power Failure:** In the event of a temporary power failure, the controller settings will be maintained for several hours. However, after a prolonged period without power, upon power restoration the display will return to 8:00AM, and the display will flash to indicate that the control panel setup needs to be performed. (See “Control Panel Setup.”)

If a temporary power failure occurs during a regeneration cycle, then a minute after power restoration, the controller will restart a regeneration cycle.

**Regeneration Mode:** A regeneration cycle can occur automatically (normally at 2:00 AM) after the softening capacity has been consumed, or it can be initiated manually by the user.

1. **To initiate a manual regeneration**, press and release the scroll button . The display will show a countdown:

Regen in 10 sec

If no other buttons are pressed, then after 10 seconds the regeneration cycle will begin.

2. It is also possible to delay the manual regeneration to night-time (2:00 AM). To do this, while the display is counting down, showing

Regen in 10 sec

press and release the scroll button  again. The display will show:

Regen @ 2:00AM

The regeneration cycle will begin at that time.

3. To cancel the initiation of a regeneration cycle (before the regeneration has begun), press the scroll button  again to return to service mode.

Once a **regeneration cycle** has begun, the display will show the current phase of the regeneration cycle.

1. First, water will be added to the brine tank if necessary:

BRINE FILL



2. Then before the regeneration backwash begins, the display will show

REGEN PENDING

3. And during the regeneration process, it will show the remaining regeneration time and the number of minutes remaining in the current cycle, such as:

Rgn: 75 Cyc3:75

During this process (which takes an hour and fifteen minutes), if there is downstream demand for water, feed water (unsoftened) will automatically be passed through the control valve to meet the demand.

4. During either an automatic or a manual regeneration, the controller can be advanced to the next phase of the regeneration by pressing the scroll button . To cancel the regeneration cycle and return to service mode, press the scroll button  repeatedly to step through the regeneration phases and exit the regeneration mode.

**Programming Mode:** Functions of programming mode are described under “Control Panel Setup.”

## Monitoring & Maintenance

The Softener should be monitored and all pertinent data recorded periodically. Data is needed to determine the operating efficiency and for performing system maintenance.

NOTE :Warranty claims can not be processed without adequate operating data and history of the softener.

Periodically test the hardness of the feed and treated water to ensure that the system is removing hardness and protecting downstream equipment.

### Salt Replenishing

**CAUTION: DO NOT RUN OUT OF SALT! FAILURE TO REPLENISH SALT WILL PREVENT THE SOFTENER FROM REMOVING HARDNESS AND PROTECTING DOWNSTREAM EQUIPMENT. MONITOR SALT LEVEL DAILY.**

Remove the Salt Lid and check the level of salt in the brine tank regularly, adding more salt when necessary. The cabinet should be kept between 1/3 and 2/3 full of salt. (Salt level should always be above the water level.) A lower level of salt can cause a failure to soften the treated water. A higher level can cause "salt bridging", a hard crust between walls of the cabinet that prevents free movement of the salt. If salt appears to be caked with a crust, bump the side of the cabinet to knock it loose.

## Operating Do's & Don'ts

### DO

- Maintain operating conditions as specified at the beginning of this manual.
- Monitor the system and keep daily logs.
- Maintain the salt level above the water level in brine tank.
- Maintain the proper water pressure for back washing.
- Position softeners or align plumbing by moving the entire unit
- Set the control panel for the local water hardness (see "Control Panel Setup")

### DON'T

- Permit oils or fats in the feed water.
- Shut down the system for extended periods.
- Exceed the required operating pressures or temperatures.
- Allow the softener to perform a regeneration cycle with insufficient water flow.
- Position softeners or align plumbing by holding just the control valve or tank fittings.
- Connect the brine tank safety overflow drain fitting directly to the control valve drain line.