

Snapshot

The **QT-1+** is a two cartridge water treatment system with two 15" Qwik-Twist cartridges, that reduces sediment down to 0.5 micron and reduces chlorine, taste & odor at a flow rate of 2.25 gpm for 22,500 gallons. The system includes a five micron PolyTrix Qwik-Twist prefilter for added protection on water supplies with excessive dirt and sediment.

System Benefits

- Improves the quality and consistency of cold and hot beverages.
- Provides 'primary' filtration for combination applications including cold and hot beverages, and ice makers.
- Reduces maintenance frequency and cost, and extends equipment life.
- Five micron Polytrix 'Qwik-Twist' prefilter provides added protection against excessive sediment found in some water supplies.
- Gradient-density depth filtration reduces dirt, rust, and other debris as small as 1/2 micron to assure clean, clear water and protect solenoids, valves and other fittings against wear and plugging.
- High capacity activated carbon filtration makes water taste great and protects equipment against corrosive chlorine.
- Reduced sediment, chlorine and taste & odor can improve beverage ingredient efficiency.
- White powder-coated mounting bracket and full-flow inlet shut-off valve makes installation simple.
- 1/4 turn QT 'Qwik-Twist' bayonet cartridges make changing the filters quick, easy and sanitary.
- All system cartridges are 'QT'-style sanitary, quick-change - no drop-in cartridges.
- Improves equipment operating efficiency.
- NSF Certified under Standard 42.

ITEM #: _____ QTY: _____

JOB NAME/NUMBER _____



Application

FOUNTAIN BEVERAGES - Up to 75 bag-in-box per month / single carbonator. Includes QT Pre-filter for water supplies with high turbidity levels.

COFFEE & TEA - Applications up to 2.25 gpm where water hardness is not a problem.

COMBINATION APPLICATIONS - Provides primary filtration for multiple points-of use.

Installation Tips

- Feed-water connection to system should be COLD only.
- Do not exceed system specifications for temperature and pressure.
- Allow 3" clearance below system for filter housing removal and cartridge replacement.
- Detailed installation, operation & maintenance manual is included with each system.
- No activation procedure or flushing is required for system to perform as specified.

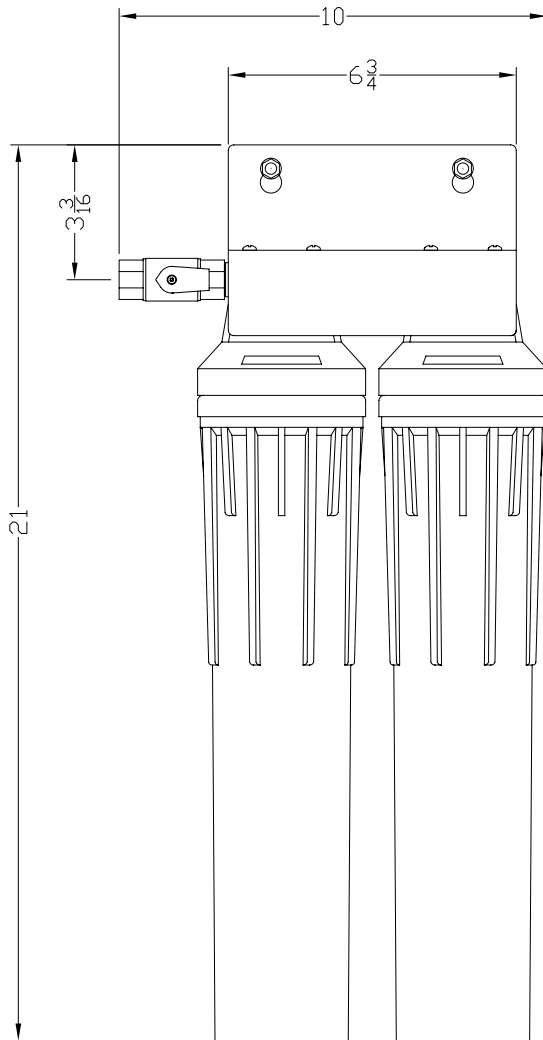

Model QT-1+ is tested and certified by NSF International against NSF/ANSI Standard 42 for the reduction of:
Standard 42: Aesthetic Effects, Chlorine Reduction
Taste and Odor Reduction
Nominal Particulate Reduction, Class 1

Dealer/Distributor Info:

► Specifications

System	
Dimensions (Height x Width X Depth, inches)	21 x 10 x 7
Connection - Inlet & Outlet	3/8" NFPT
Operating Pressure Range	10-125 psi (0.7 -8.6 bar)
Inlet Water Temperature Range	35° -100° F (2° -38° C)
Shipping Weight	12 lbs.
Performance	
Chlorine, Taste and Odor Reduction Capacity	22,500 gals. (85,162 liters)
Service Flow Rate	2.25 gpm (8.5 lpm)
Sediment Reduction	.5 micron (nominal)

Optional Flush Valve Kit - Part #: 160-52912
Optional Gauge Kit - Part #: 160-52904

► Replacement Cartridge(s)

Model	Part Number	Qty
S5-Q	300-05802	1
CTO-Q	300-05830	1

It is recommended that filters be changed every six months, when capacity is reached or when effluent pressure or flow becomes inadequate.

This product is for commercial use only and must be installed and maintained according to manufacturers guidelines.

Do not use on water that is microbiologically unsafe or of unknown quality without adequate disinfection before or after the system.

► Warranty

Systems have a 3 year warranty against defects in material and workmanship. Contact OptiPure customer service or go to www.optipurewater.com

OptiPure, Mfg. by Procam Controls, Inc.
2605 Technology Dr., Bldg 300
Plano, TX 75074
p: 972.881.9797; f: 972.422.6262
www.optipurewater.com