

Snapshot

The **QT-1** is a single cartridge water treatment system with a 15" Qwik-Twist cartridge that reduces sediment down to 0.5 micron and reduces chlorine, taste & odor at a flow rate of 2.25 gpm for 22,500 gallons.

System Benefits

- Improves the quality and consistency of cold and hot beverages.
- Reduces maintenance frequency and cost, and extends equipment life.
- Gradient-density depth filtration reduces dirt, rust, and other debris as small as 1/2 micron to assure clean, clear water and protect solenoids, valves and other fittings against wear and plugging.
- High capacity activated carbon filtration makes water taste great and protects equipment against corrosive chlorine.
- Reduced sediment, chlorine and taste & odor can improve beverage ingredient efficiency.
- Mounting bracket and full-flow inlet shut-off valve makes installation simple.
- 1/4 turn QT 'Qwik-Twist' bayonet cartridges make changing the filter quick, easy and sanitary.
- NSF Certified under Standard 42.



ITEM #: _____ QTY: _____
JOB NAME/NUMBER _____

Application

FOUNTAIN BEVERAGES - Up to 75 bag-in-box per month / single carbonator.

COFFEE & TEA - Applications up to 2.25 gpm where water hardness is not a problem.

DRINKING WATER - Up to 2.25 gpm flow rate.

Installation Tips

- Feed-water connection to system should be COLD only.
- Do not exceed system specifications for temperature and pressure.
- Allow 3" clearance below system for filter cartridge removal and replacement.
- Detailed installation, operation & maintenance manual is included with each system.
- No activation procedure or flushing is required for system to perform as specified.

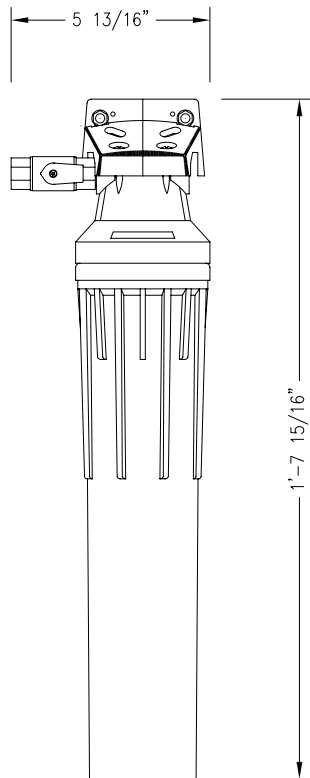

Model QT-1 is tested and certified by NSF International against NSF/ANSI Standard 42 for the reduction of: Standard 42: Aesthetic Effects, Chlorine Reduction, Taste and Odor Reduction, Nominal Particulate Reduction, Class 1

Dealer/Distributor Info:

► Specifications

System	
Dimensions (Height x Width X Depth, inches)	19 15/16" x 5 13/16" x 4 1/6"
Connection - Inlet & Outlet	3/8" NFPT
Operating Pressure Range	10-125 psi (0.7 -8.6 bar)
Inlet Water Temperature Range	35° -100° F (2° -38° C)
Shipping Weight	5 lbs.
Performance	
Chlorine, Taste and Odor Reduction Capacity	22,500 gals. (85,162 liters)
Service Flow Rate	2.25 gpm (8.5 lpm)
Sediment Reduction	.5 micron (nominal)
Scale & Corrosion Inhibitor	N/A

Optional Flush Valve Kit - Part #: 160-52912
Optional Gauge Kit - Part #: 160-52904

► Replacement Cartridge(s)

Model	Part Number	Qty
CTO-Q	300-05830	1

It is recommended that filters be changed every six months, when capacity is reached or when effluent pressure or flow becomes inadequate.

This product is for commercial use only and must be installed and maintained according to manufacturers guidelines.

Do not use on water that is microbiologically unsafe or of unknown quality without adequate disinfection before or after the system.

► Warranty

Systems have a 3 year warranty against defects in material and workmanship. Contact OptiPure customer service or go to the OptiPure website for a copy of the warranty.

OptiPure, Mfg. by Procam Controls, Inc.
2605 Technology Dr., Bldg 300
Plano, TX 75074
p: 972.881.9797; f: 972.422.6262
www.optipurewater.com