

Snapshot

The **OptiPure QT2+MP** Multi-Point filtration system provides a combination of filters to meet the requirements of different equipment applications including fountain beverages, ice and coffee. The system includes four Qwik-Twist cartridges. The first cartridge is a 5 micron QT sediment prefilter, followed by two 'primary' cartridges that reduce sediment down to 0.5 micron and reduces chlorine, taste & odor at a flow rate a 4.5 gpm for 45,000 gallons. The fourth cartridge is a 'secondary' filter that provides added scale protection with IsoNet® for ice machines and coffee brewers.

System Benefits

- Dual system outlets provide 'primary' filtration for cold beverages and additional 'secondary' filtration for ice machines and coffee brewers.
- All system cartridges are 1/4 turn 'Qwik-Twist' cartridges to make changing the filters quick, easy and sanitary. No clear sumps or drop-in style filters to replace.
- Primary QT filtration takes out dirt, rust and other debris as small as 1/2 micron to assure clean, clear water and to protect solenoids, valves and other fittings against wear and plugging.
- Primary filtration includes high capacity activated carbon to reduce chlorine, taste & odor to make great tasting beverages.
- Secondary QT filter provides the added protection of IsoNet® - OptiPure patented scale inhibiting technology protects ice and coffee equipment from scale and corrosion.
- Additional PolyTrix 5 Micron Sediment Pre-Filter provides added protection against excessive sediment found in some water supplies.
- Improves the quality and consistency of cold and hot beverages and ice.
- Reduces maintenance frequency and cost, and extends equipment life.
- Compact design, heavy duty mounting bracket and full-flow inlet & outlet shut-off valve makes installation simple.
- Built-in pressure gauge allows visual monitoring of operating pressure.

ITEM #: _____ QTY: _____
JOB NAME/NUMBER _____



Application

COMBINATION APPLICATIONS - *For use with multiple equipment applications where combined filtration technologies are needed to provide water for different types of equipment including fountain and cold beverages, ice machines and coffee brewers.*

Installation Tips

- Feed-water connection to system should be COLD only.
- Do not exceed system specifications for temperature and pressure.
- Allow 3" clearance below system for filter cartridge removal and replacement.
- Detailed installation, operation & maintenance manual is included with each system.
- No activation procedure or flushing is required for system to perform as specified.

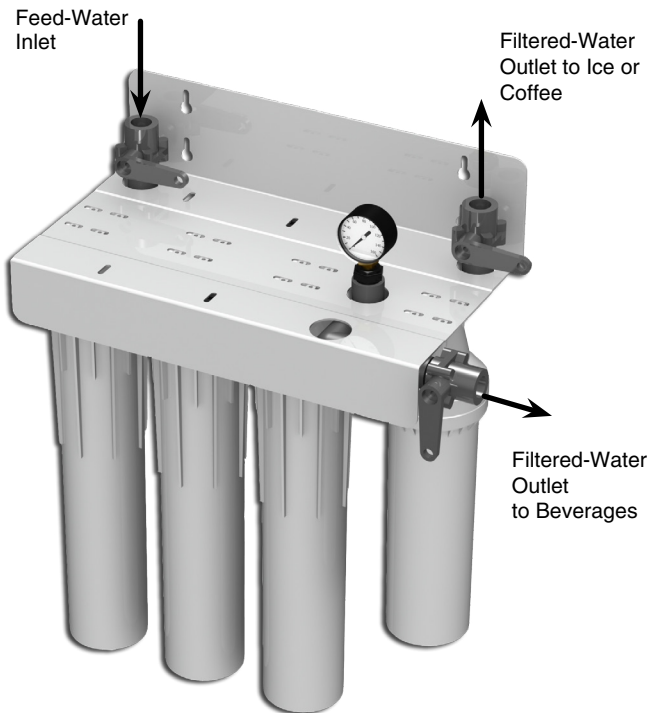
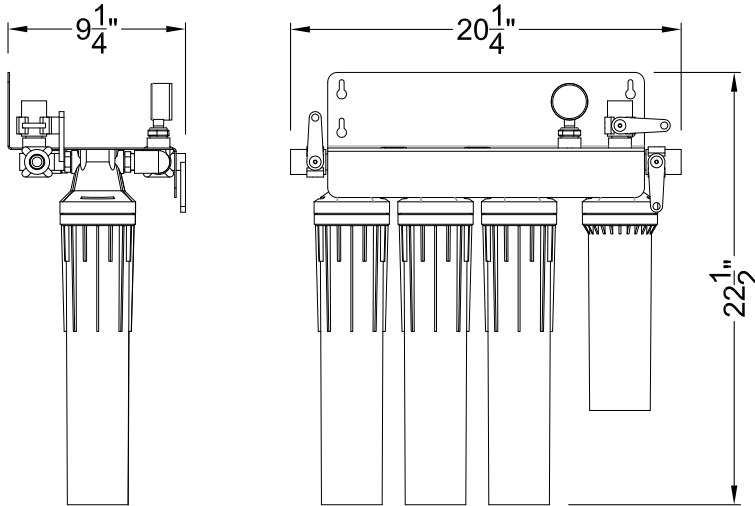

► Specifications

System	
Dimensions (Height x Width X Depth, inches)	22.5" x 20.3" x 9.3"
Connection - Inlet & Outlet	1/2" NFPT
Operating Pressure Range	10-125 psi (0.7 -8.6 bar)
Inlet Water Temperature Range	35° -100° F (2° -38° C)
Shipping Weight	25 lbs.
Performance	
Chlorine, Taste and Odor Reduction Capacity	45,000 gals. (170,325 liters)
Service Flow Rate	4.5 gpm (17 lpm)
Sediment Reduction	.5 micron (nominal)
Scale & Corrosion Inhibitor	IsoNet® (100 grams)

Optional Flush Valve Kit - Part #: 160-52912

► Replacement Cartridge(s)

Model	Part Number	Qty
S5-Q	300-08105	1
CTO-Q	300-08115	2
PTS-Q	300-08215	1

It is recommended that filters be changed every six months, when capacity is reached or when effluent pressure or flow becomes inadequate.

This product is for commercial use only and must be installed and maintained according to manufacturers guidelines.

Do not use on water that is microbiologically unsafe or of unknown quality without adequate disinfection before or after the system.

► Warranty

Systems have a 3 year warranty against defects in material and workmanship. For complete warranty information contact OptiPure customer service or go to www.optipurewater.com.

OptiPure

div. of Procam Controls, Inc.

2605 Technology Dr., Bldg 300 Plano, TX 75074

p: 972.881.9797; f: 972.422.6262

www.optipurewater.com

QT2+MPspec814

Dealer/Distributor Info: