

NOTICE TO INSTALLER:

DO NOT DISCARD THIS MANUAL AFTER INSTALLATION. THIS MANUAL CONTAINS IMPORTANT OPERATION, MAINTENANCE AND PRECAUTIONARY INFORMATION. PLEASE PRESENT THIS MANUAL TO USER/OPERATOR/OWNER AFTER INSTALLATION.

IT IS STRONGLY ENCOURAGED THAT YOU READ THIS MANUAL BEFORE INSTALLING SYSTEM TO ENSURE THE BEST POSSIBLE INSTALLATION.

INSTALLATION MUST CONFORM TO ALL LOCAL AND STATE PLUMBING CODES AND REGULATIONS.

CONNECT SYSTEM TO COLD WATER SUPPLY ONLY. WATER TEMP. CAN NOT EXCEED 100°F/28°C.

SYSTEM MUST BE INSTALLED IN A VERTICAL AND UPRIGHT POSITION.

SCALEX 2 SYSTEMS MUST NOT BE USED IN CONJUNCTION WITH POLYPHOSPHATE OR ANY OTHER SCALE INHIBITOR.

DO NOT USE WITH WATER THAT IS MICROBIOLOGICALLY UNSAFE OR OF UNKNOWN QUALITY WITHOUT ADEQUATE DISINFECTION BEFORE OR AFTER THE SYSTEM.

NOTICE TO USER/OPERATOR/OWNER:

PLEASE COMPLETE THE PRODUCT REGISTRATION CARD AND MAIL OR FAX TO MANUFACTURER. PLEASE RETAIN THIS MANUAL FOR FUTURE REFERENCE FOR PARTS, MAINTENANCE OR TROUBLE-SHOOTING.

IT IS RECOMMENDED THAT ALL PERSONNEL RESPONSIBLE FOR OPERATION AND MAINTENANCE OF THIS PRODUCT READ THE PRECAUTIONS, OPERATION AND MAINTENANCE SECTIONS OF THIS MANUAL.

Introduction

Your new OptiPure ScaleX2 FoodService Filtration System will cleanse and condition the tap water providing optimum water characteristics for their specified applications. The result is reduced equipment maintenance requirements, longer equipment life and improved quality & consistency of your products. Proper system installation and routine filter changes will ensure years of trouble-free operation and performance.

The OptiPure System is built with the finest and most advanced materials and each system is quality inspected and pressure tested prior to shipment. With proper installation and routine maintenance, you will have years of trouble-free operation.

Please refer to this manual when performing routine filter changes. The instructions make periodic maintenance quick and easy, and ensure you will receive maximum benefit from your system.

System Specifications

Maximum Pressure: 125 psi/8.6 bar

Maximum Temperature: 100°F/38°C, Min.: 35°F/2°C

Inlet/Outlet Connections: 3/4" fnpt

Service Flow Rate: 1-4 gpm

Gallon Rating: SX2-22B: 65,000 gals. for the CTO-20B, 1 year for the SCLX2-4

Capacity: Change the CTO-20B cartridge at gallon rating or at least every 6 months or when pressure gauge needle enters the red zone on the outlet gauge while water is flowing through the filter system under normal operating conditions. The SCLX2-4 cartridge does not have a grain removal capacity, however, naturally occurring organics present in the water will gradually degrade the effectiveness of this cartridge. Change the SCLX2-4 cartridge at least once a year.

Installation Precautions

- Do **NOT** install system on line pressure above 125 psi.
- Do **NOT** install system on HOT water line. Failure to limit line temperature to 100°F may result in housing failure and damage.
- Do **NOT** install the system backwards with the feed water line connected to the outlet.
- Do **NOT** use liquid pipe compounds for fitting connections. USE two to three wraps of teflon tape.
- Do **NOT** solder plumbing connections attached to filter housing or inlet valve. Inlet valve and filter housing will be damaged by high temperature.
- Do **NOT** allow system to freeze. Turn off water supply to housing and drain housing if temperature falls below 32°F.
- Do **NOT** install system in direct sunlight or where system is exposed to harsh chemicals or may be subjected to being struck by moving equipment, carts, mops or any other item that may cause damage.
- **ALLOW** a minimum of 3" under the housing to allow for filter replacement.
- **IF** water hammer is evident, install water hammer arrestors before OptiPure unit.
- Do **NOT** overtighten fitting connections into inlet valve or housing outlet.
- **Always** back-up valves and fittings with a wrench when installing a fitting to avoid turning the valve.
- Do **NOT** install the unit behind equipment where it may be difficult to access the system for filter replacement.

Position the OptiPure unit in a suitable location. The direction of flow through the OptiPure unit is always left to right; keep this in mind when determining installation location. Do NOT mount the OptiPure system near any source of heat. Also, do not mount the system above any device or area that would be adversely affected by water.

Installation Procedure (See Installation Drawings for Detail)

1. Turn off all equipment to be fed by the OptiPure System, locate water supply cut-off valve and turn off.
2. **Determine if water line has an existing water treatment system. Is so, examine system for use of poly phosphate or other scale inhibitors. ScaleX2 will not be effective if used in conjunction with other scale inhibitors. Remove the scale inhibitors from the water line or discontinue installation.**
3. Install a 1/2" full-flow ball valve on the water supply side that will feed the water system.
4. Anchor the OptiPure System on a wall stud or suitable mounting material spanning wall studs. **System must be vertical and upright.**
5. Run a suitable line from the 1/2" full-flow ball valve at the tap water source to the inlet ball valve on the left side of the ScaleX2 system. Use 2-3 wraps of teflon tape and brace the inlet ball valve on the system with a wrench when connecting the feed water line. **NOTE: DO NOT OVERTIGHTEN CONNECTION FITTING INTO BALL VALVE.**
6. Select the appropriate size tubing for the equipment being fed and connect it to the outlet of the ScaleX2 System. **NOTE: DO NOT connect the tubing to the equipment at this time. Prior to making connection to the equipment this line will be used to facilitate flushing the system. As an option, a drain valve in a tee on the outlet side of the OptiPure system could be provided in the line to facilitate flushing when changing filters.**
7. With System inlet valve closed, slowly open the 1/2" full-flow ball valve at the tap water source. Check for leaks.
8. If a drain valve was not installed on the outlet side of the system, hold the tubing that will connect to equipment in a clean bucket or over sink or drain. Open the system inlet feed valve and allow water to flush through system for 5 minutes at the specified system flow rate to allow air and any carbon fines to escape. **NOTE: NO ACTIVATION IS REQUIRED FOR THE OPTIPURE SYSTEM TO PERFORM PROPERLY. FLUSHING IS RECOMMENDED TO ALLOW AIR TO ESCAPE THE SYSTEM AND REMOVE ANY CARBON FINES PRIOR TO CONNECTING TO EQUIPMENT.**
9. Make certain that the end of the tubing to be connected to the equipment is clean and sanitary.

Installation Procedure - Continued

10. Connect tubing to equipment. Open all water supply valves and check for leaks.
11. If no leaks turn on equipment and check for normal operation.
12. Attach the Service Log to the Installed OptiPure System and fill in install date.

Installation Drawings & Dimensions

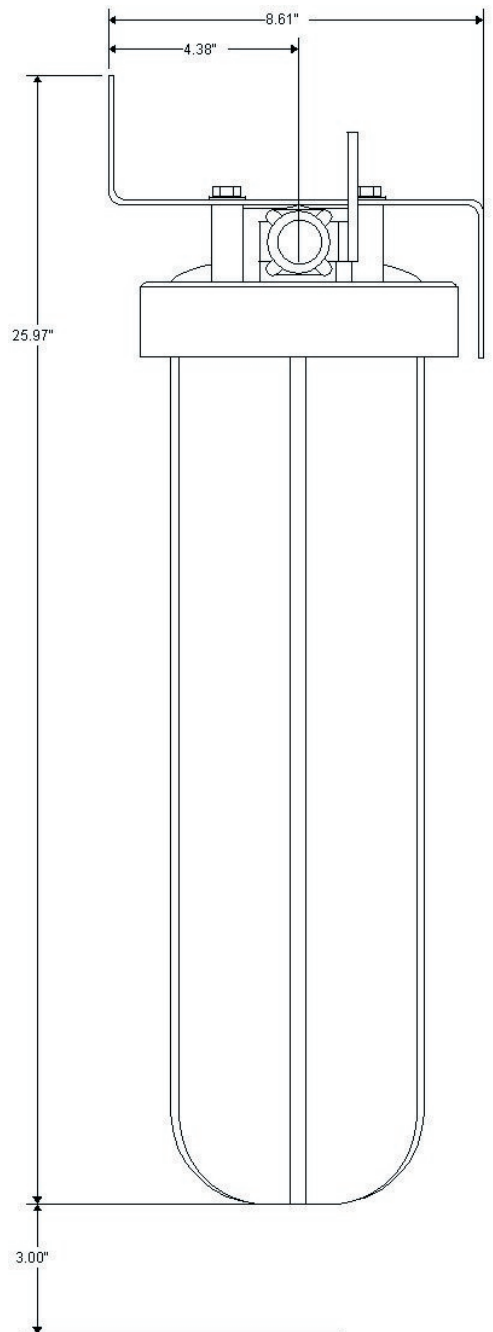
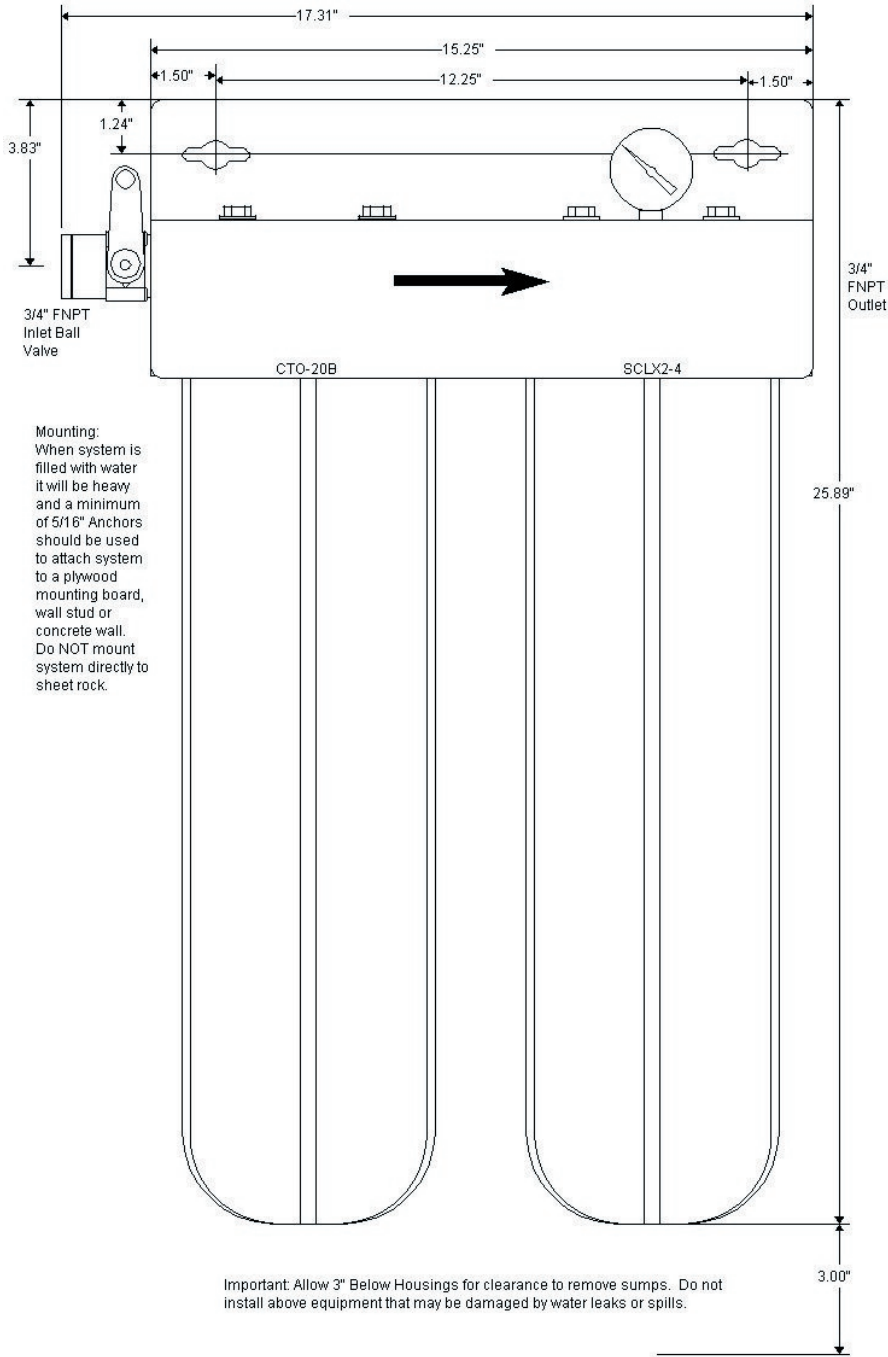

Operation

With adequate pressure, normal operation of the ScaleX2 System is completely automatic. Dependable operation involves only monitoring of outlet pressure, periodic filter changes and service documentation.

Pressure Gauge Monitoring

Periodically monitor the pressure gauge on the ScaleX2 unit. If the needle on the gauge ever enters the red zone it may be an indication that the filters have become clogged with sediment. Ideally the pressure should never drop into the red zone.

Maintenance

The only routine maintenance your ScaleX2 System should ever require is periodic filter cartridge changes or replacement sump O-rings. Filter changes are necessary for optimum performance of your foodservice equipment. If the system sizing recommendations have been followed the ScaleX2 System is designed to provide a six (6) month filter replacement interval on most tap water for the CTO-20B cartridge and the ScaleX2 Cartridge should last one (1) year..

Filter Change Frequency

Several situations will mandate filter changes. Complete filter sets should be changed when any of the following apply:

- Six (6) to twelve (12) Months have passed since unit installation or previous filter change.
- Reduced water flow.
- Pressure gauge needle enters the red zone or drops below pressure required for equipment operation.

If filter change frequency is less than 6 months due to pressure drop, it may be necessary to add additional prefiltration or evaluate system sizing recommendations.

Filter Cartridge Replacement Procedure

IMPORTANT: Determine whether all equipment connected to the ScaleX2 System must be turned off prior to shutting off water supply from filters.

1. If required, turn off equipment.
2. Turn OFF water to ScaleX2 System by closing Inlet Ball Valve.
3. Press the red button to release pressure.
4. Remove housing(s) - use filter wrench if necessary.
5. Clean inside of housing sumps with warm water. If desired, disinfect housings using a teaspoon of household bleach in a filter bowl of water. Let stand 5 minutes, and then discard.
6. Insert new cartridges into filter housings. Match cartridge model numbers to model numbers on bracket.
7. Make certain the O-ring is properly positioned and reinstall filter housings (hand tighten only). Check O-ring for damage and replace if damaged or distorted.
8. Slightly open the inlet ball valve; push the red pressure relief button to release trapped air until a small amount of water comes out - release the red button and fully open the ball valve.
9. Open the flush valve downline from the filter housing (if equipped) and flush the new cartridges to drain or bucket for five (5) minutes or until water runs clear. If no flush valve is present, disconnect line from equipment to flush to drain.
10. **VERY IMPORTANT:** With water supply inlet valve OPEN and water flow confirmed, turn on connected equipment. Failure to supply water to equipment may cause serious damage.
11. Record filter change on the service log or at FilterTrak.

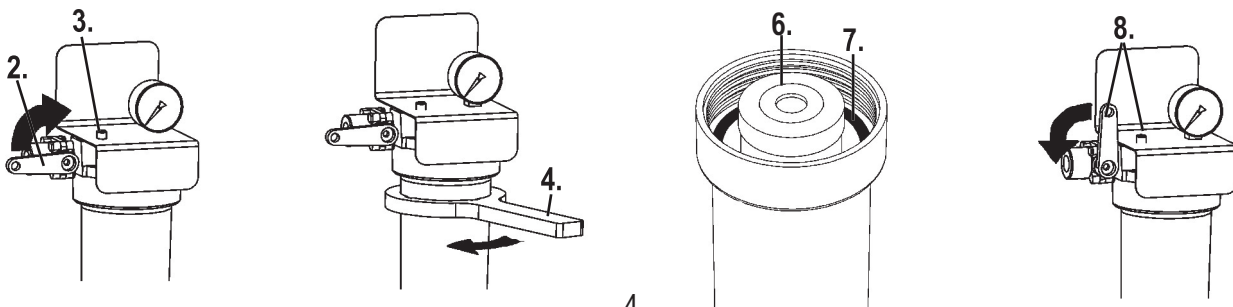

Replacement Filter Cartridges

OptiPure Filter Systems are designed, tested, and certified with FilterXpress filter cartridges with proven performance, size and operating capacities. Use of replacement cartridges other than those specified will void warranties, certifications and may compromise equipment protection, water quality and cartridge life.

Replacement Parts for: **SX2-22B**

Drawing ID #	Part #	Description
1	600-10013	Housing
2	600-10014	Housing, w/Gauge Port & PR
1/2a	600-99004	O-Ring
1/2b	600-90022	Sump Only
3	520-12006	Valve, Inlet Ball 3/4"
4	530-20019	Gauge, Pressure 0-160 psi
5	520-03235	Flow Restrictor, 3.5 gpm
6	590-01016	Bracket, White PC
7	800-00255	Screw
8	252-20420	CTO-20B Replacement Cartridge
9	252-60220	SCLX2-4 ScaleX2 Cartridge
	600-99009	Wrench, Housing
	600-99205	Pressure Relief Button Kit

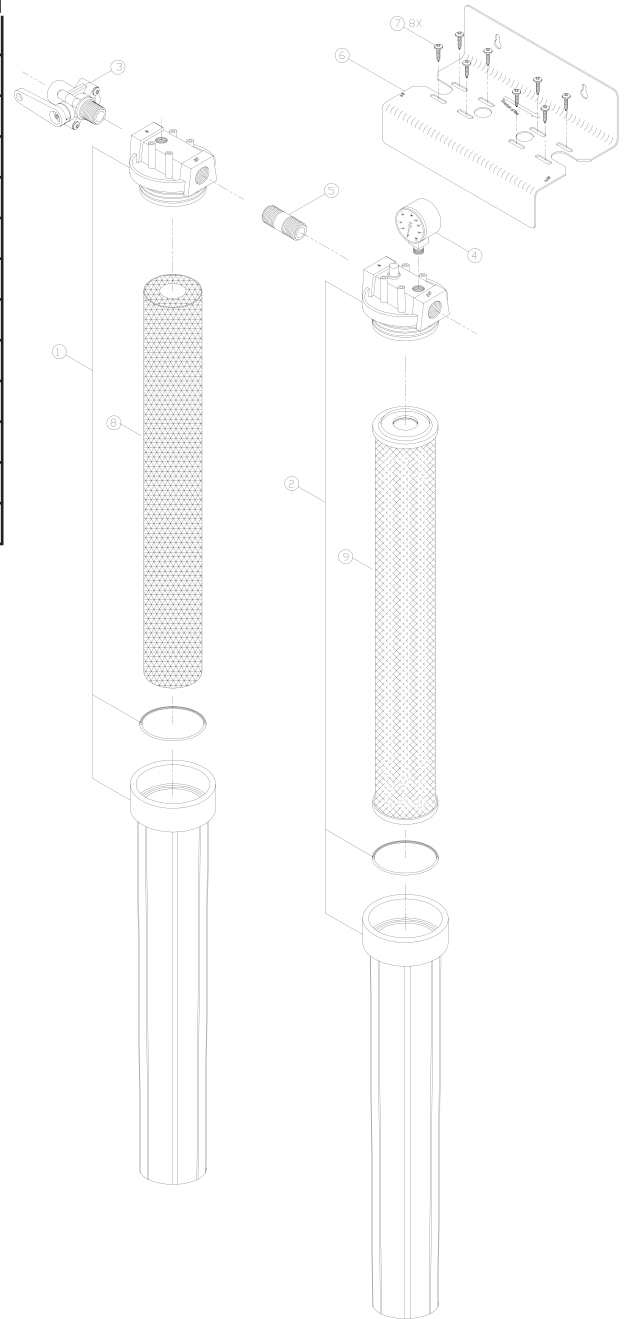

Questions, Problems or Assistance?
Call, email or write to:

FilterXpress div. of Procam Controls, Inc.
2605 Technology Dr. Bldg. 300 Plano, TX 75074 USA
P: 972.881.9797 F: 972.422.6262
email: procam@filterxpress.com